

Compensating for the Effects of Input Capacitance on VFB and CFB Op Amps Used in Current-to-Voltage Converters

Fast op amps are useful as current-to-voltage converters in such applications as high speed photodiode preamplifiers and current-output DAC buffers. A typical application using a VFB op amp as an I/V converter is shown in Figure 1.

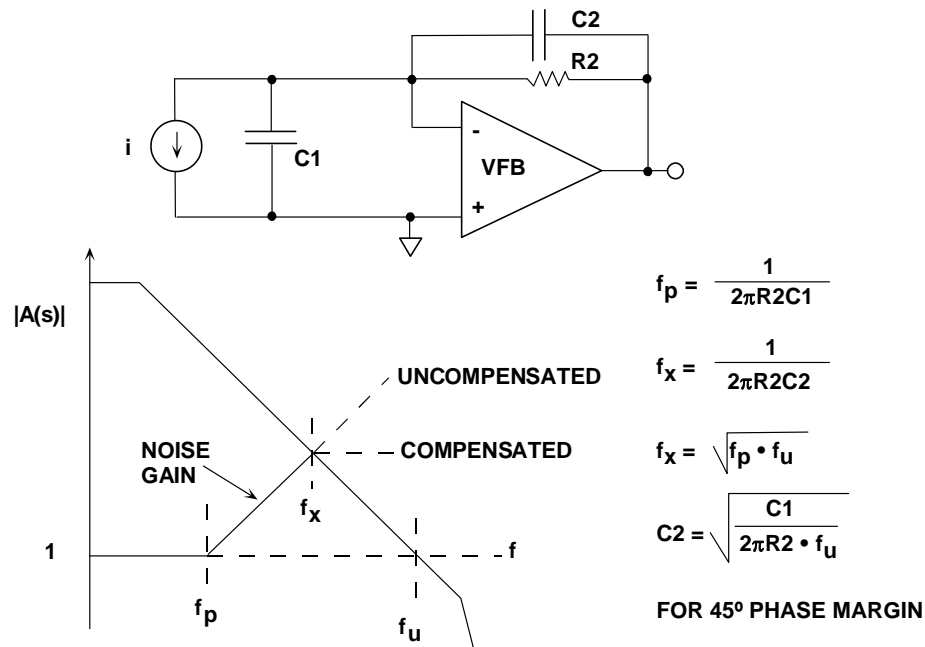

Figure 1: Compensating for Input Capacitance in a Current-to-Voltage Converter Using VFB Op Amp

The net input capacitance, C1, forms a pole at a frequency f_p in the noise gain transfer function as shown in the Bode plot, and is given by:

$$f_p = \frac{1}{2\pi R_2 C_1} \quad \text{Eq. 1}$$

If left uncompensated, the phase shift at the frequency of intersection, f_x , will cause instability and oscillation. Introducing a zero at f_x by adding feedback capacitor C2 stabilizes the circuit and yields a phase margin of about 45°. The location of the zero is given by:

$$f_x = \frac{1}{2\pi R_2 C_2} \quad \text{Eq. 2}$$

Although the addition of C2 actually decreases the pole frequency slightly, this effect is negligible if $C2 \ll C1$. The frequency f_x is the geometric mean of f_p and the unity-gain bandwidth frequency of the op amp, f_u ,

$$f_x = \sqrt{f_p \cdot f_u} \quad \text{Eq. 3}$$

Combining Eq. 2 and Eq. 3 and solving for C2 yields:

$$C2 = \sqrt{\frac{C1}{2\pi R2 \cdot f_u}} \quad \text{Eq. 4}$$

This value of C2 will yield a phase margin of about 45°. Increasing the capacitor by a factor of 2 increases the phase margin to about 65°.

In practice, the optimum value of C2 may be optimized experimentally by varying it slightly, to optimize the output pulse response.

A similar analysis can be applied to a CFB op amp as shown in Figure 2 below. In this case, however, the low inverting input impedance, R_O , greatly reduces the sensitivity to input capacitance. In fact, an ideal CFB with zero input impedance would be totally insensitive to any amount of input capacitance!

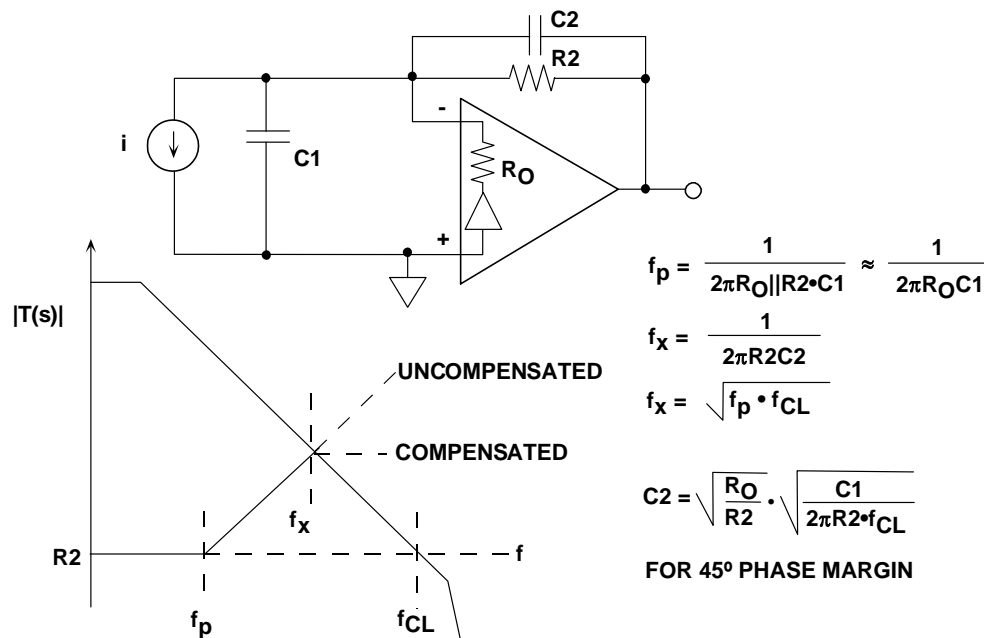

Figure 2: Current-to-Voltage Converter Using a CFB Op Amp

The pole caused by C1 occurs at a frequency f_p :

$$f_p = \frac{1}{2\pi(R_O \parallel R_2)C_1} \approx \frac{1}{2\pi R_O C_1}. \quad \text{Eq. 5}$$

This pole frequency will generally be much higher than the case for a VFB op amp, and the pole can be ignored completely if it occurs at a frequency greater than the closed-loop bandwidth of the op amp.

We next introduce a compensating zero at the frequency f_x by inserting the capacitor C2:

$$f_x = \frac{1}{2\pi R_2 C_2}. \quad \text{Eq. 6}$$

As in the case for VFB, f_x is the geometric mean of f_p and f_{cl} :

$$f_x = \sqrt{f_p \cdot f_{cl}}. \quad \text{Eq. 7}$$

Combining Eq. 6 and Eq. 7 and solving for C2 yields:

$$C_2 = \sqrt{\frac{R_O}{R_2}} \cdot \sqrt{\frac{C_1}{2\pi R_2 \cdot f_{cl}}}. \quad \text{Eq. 8}$$

There is a significant advantage in using a CFB op amp in this configuration as can be seen by comparing Eq. 8 with the similar equation for C2 required for a VFB op amp, Eq. 4. If the unity-gain bandwidth product of the VFB is equal to the closed-loop bandwidth of the CFB (at the optimum R_2), then the size of the CFB compensation capacitor, C2, is reduced by a factor of $\sqrt{(R_2/R_O)}$.

A comparison in an actual application is shown in Figure 3 below. The full scale output current of the DAC is 4mA, the net capacitance at the inverting input of the op amp is 20 pF, and the feedback resistor is 500 Ω . In the case of the VFB op amp, the pole due to C1 occurs at 16 MHz. A compensating capacitor of 5.6 pF is required for 45° of phase margin, and the signal bandwidth is 57 MHz.

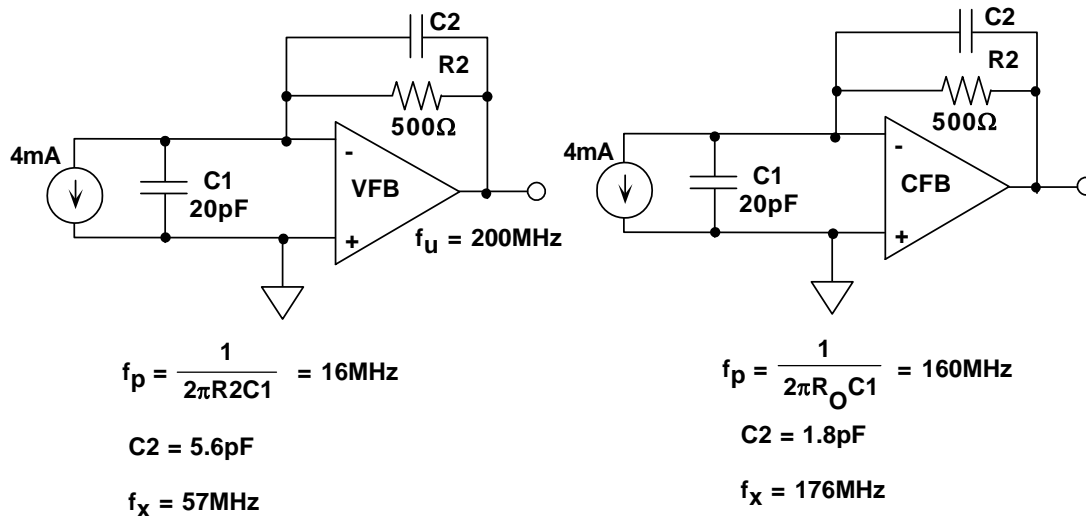

Figure 3: CFB Op Amp is Relatively Insensitive to Input Capacitance When Used as an I/V Converter

For the CFB op amp, however, because of the low inverting input impedance ($R_O = 50 \Omega$), the pole occurs at 160 Mhz, the required compensation capacitor is about 1.8 pF, and the corresponding signal bandwidth is 176 MHz. In practice, the pole frequency is so close to the closed-loop bandwidth of the op amp that it could probably be left uncompensated.

It should be noted that a CFB op amp's relative insensitivity to inverting input capacitance is when it is used in the inverting mode. In the non-inverting mode, however, even a few picofarads of stray capacitance on the inverting input can cause significant gain-peaking and potential instability.

Another advantage of the low inverting input impedance of the CFB op amp is when it is used as an I/V converter to buffer the output of a high speed current output DAC. When a step function current (or DAC switching glitch) is applied to the inverting input of a VFB op amp, it can produce a large voltage transient until the signal can propagate through the op amp to its output and negative feedback is regained. Back-to-back Schottky diodes are often used to limit this voltage swing as shown in Figure 4 below. These diodes must be low capacitance, small geometry devices because their capacitance adds to the total input capacitance.

A CFB op amp, on the other hand, presents a low impedance (R_O) to fast switching currents even before the feedback loop is closed, thereby limiting the voltage excursion without the requirement of the external diodes. This greatly improves the settling time of the I/V converter.

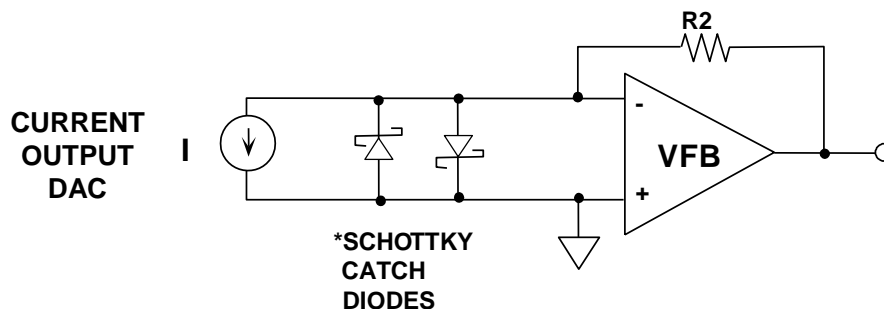

***NOT REQUIRED FOR CFB OP AMP
BECAUSE OF LOW INVERTING INPUT IMPEDANCE**

Figure 4: Low Inverting Input Impedance of CFB Op Amp Helps Reduce Effects of Fast DAC Transients

REFERENCES

1. Hank Zumbahlen, *Basic Linear Design*, Analog Devices, 2006, ISBN: 0-915550-28-1. Also available as [Linear Circuit Design Handbook](#), Elsevier-Newnes, 2008, ISBN-10: 0750687037, ISBN-13: 978-0750687034. Chapter 1.
2. Walter G. Jung, *Op Amp Applications*, Analog Devices, 2002, ISBN 0-916550-26-5, Also available as [Op Amp Applications Handbook](#), Elsevier/Newnes, 2005, ISBN 0-7506-7844-5. Chapter 1.

Copyright 2009, Analog Devices, Inc. All rights reserved. Analog Devices assumes no responsibility for customer product design or the use or application of customers' products or for any infringements of patents or rights of others which may result from Analog Devices assistance. All trademarks and logos are property of their respective holders. Information furnished by Analog Devices applications and development tools engineers is believed to be accurate and reliable, however no responsibility is assumed by Analog Devices regarding technical accuracy and topicality of the content provided in Analog Devices Tutorials.