

## Video Multiplexers and Crosspoint Switches

### VIDEO MULTIPLEXERS

In order to meet stringent specifications of bandwidth flatness, differential gain and phase, and 75  $\Omega$  drive capability, high speed complementary bipolar processes are more suitable than CMOS processes for video switches and multiplexers. Traditional CMOS switches and multiplexers suffer from several disadvantages at video frequencies. Their switching time (typically 50 ns or so) is not fast enough for today's video applications, and they require external buffering in order to drive typical video loads. In addition, the small variation of the CMOS switch on-resistance with signal level ( $R_{ON}$  modulation) introduces unwanted distortion in differential gain and phase. Multiplexers based on complementary bipolar technology offer a better solution at video frequencies. The tradeoffs, of course, are higher power and cost.

Functional block diagrams of the [AD8170/AD8174/AD8180/AD8182](#) bipolar video multiplexer are shown in Figure 1. The [AD8183/AD8185](#) video multiplexer is shown in Figure 2. These devices offer a high degree of flexibility and are ideally suited to video applications, with excellent differential gain and phase specifications. Switching time for all devices in the family is 10ns to 0.1%. The [AD8186/AD8187](#) are single-supply versions of the AD8183/AD8185. Note that these bipolar multiplexers are not bi-directional.

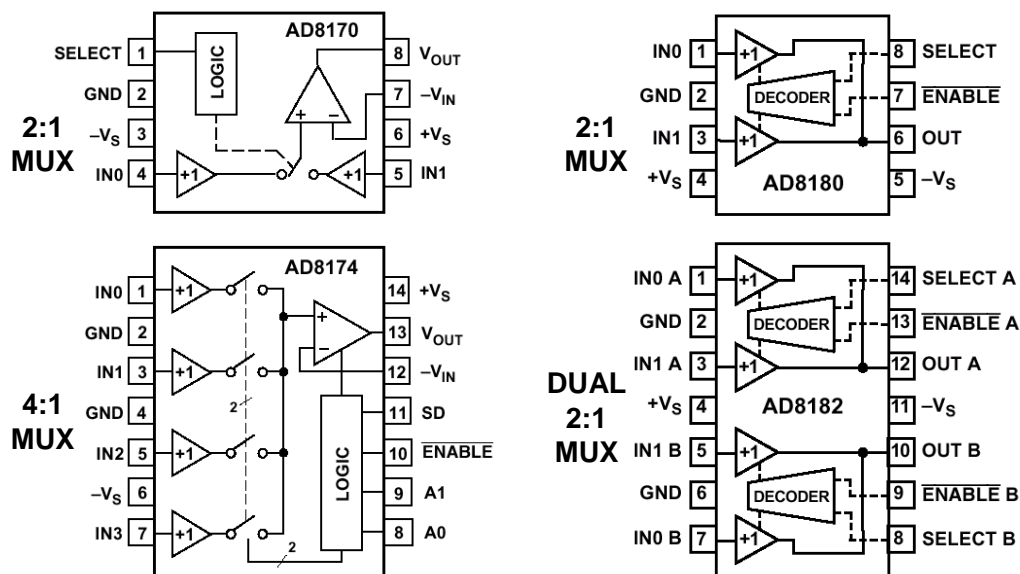

**Figure 1: AD8170/8174/8180/8182 Bipolar Video Multiplexers**

The [AD8170/AD8174](#) series of muxes include an on-chip current feedback op amp output buffer whose gain can be set externally. Off channel isolation and crosstalk are typically greater than 80 dB at 5 MHz for the entire family.

Figure 3 shows an application circuit for three AD8170 2:1 muxes, where a single RGB monitor is switched between two RGB computer video sources.

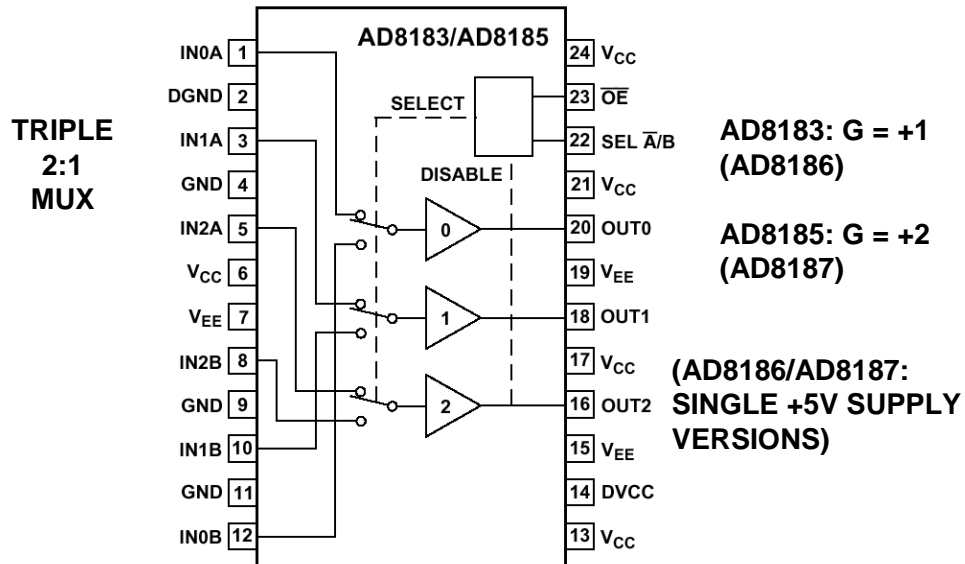

Figure 2: AD8183/AD8185 Triple 2:1 Video Multiplexers

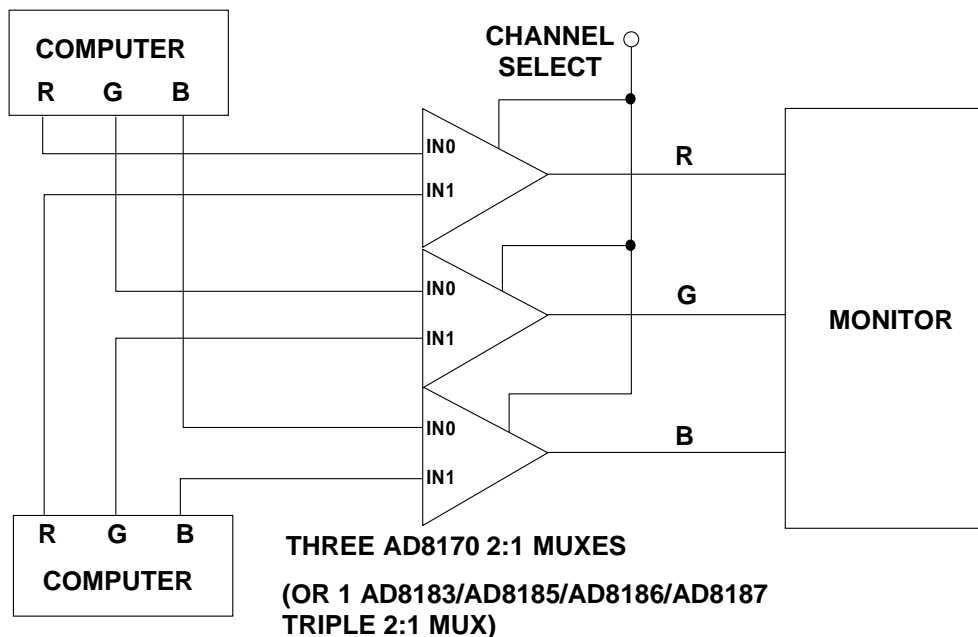
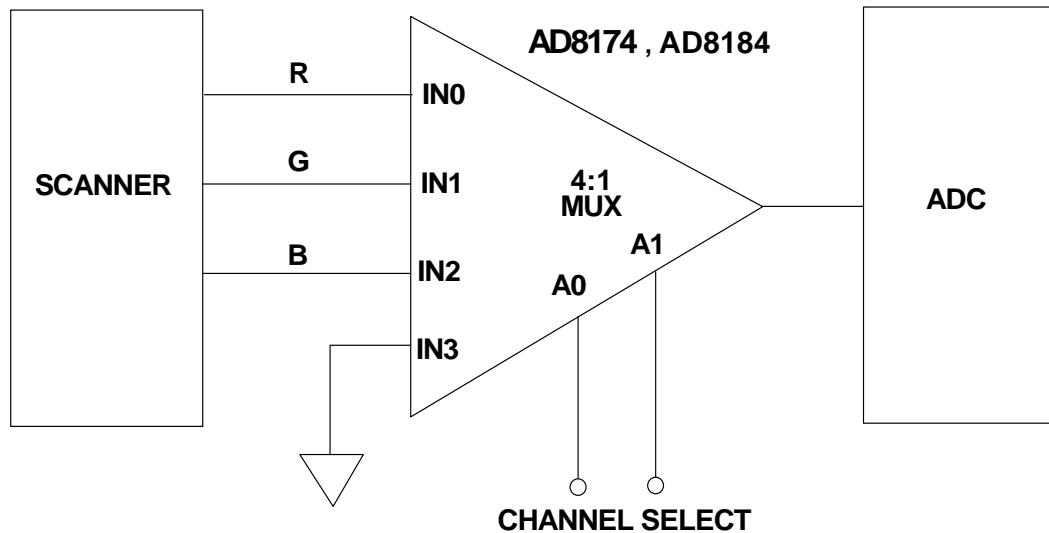

Figure 3: Dual Source RGB Multiplexer Using Three 2:1 Muxes

In this setup, the overall effect is that of a three-pole, double-throw switch. The three video sources constitute the three poles, and either the upper or lower of the video sources constitute the two switch states. Note that the circuit can be simplified by using a single [AD8183](#), [AD8185](#), [AD8186](#), or [AD8187](#) triple dual input multiplexer.

The [AD8174](#) or [AD8184](#) 4:1 mux is used in Figure 4, to allow a single high speed ADC to digitize the RGB outputs of a scanner.



**Figure 4: Digitizing RGB Signals with One ADC and a 4:1 Mux**

The RGB video signals from the scanner are fed in sequence to the ADC, and digitized in sequence, making efficient use of the scanner data with one ADC.

## VIDEO CROSSPOINT SWITCHES

The [AD8116](#) extends the multiplexer concepts to a fully integrated, 16×16 buffered video crosspoint switch matrix (Figure 5). The 3-dB bandwidth is greater than 200 MHz, and the 0.1-dB gain flatness extends to 60 MHz. Channel switching time is less than 30 ns to 0.1%. Channel-to-channel crosstalk is -70 dB measured at 5 MHz. Differential gain and phase is 0.01% and 0.01° for a 150-Ω load. Total power dissipation is 900 mW on ±5 V.

The AD8116 includes output buffers that can be put into a high impedance state for paralleling crosspoint stages so that the off channels do not load the output bus. The channel switching is performed via a serial digital control that can accommodate "daisy chaining" of several devices. The AD8116 package is a 128-pin 14 mm × 14 mm LQFP.

Other members of the crosspoint switch family include the [AD8108/AD8109](#) 8 × 8 crosspoint switch; the [AD8110/AD8111](#), 260-MHz, 16 × 8, buffered crosspoint switch; the [AD8113](#)

audio/video 60-MHz,  $16 \times 16$  crosspoint switch; and the [AD8114/AD8115](#) low cost 225-MHz,  $16 \times 16$ , crosspoint switch.

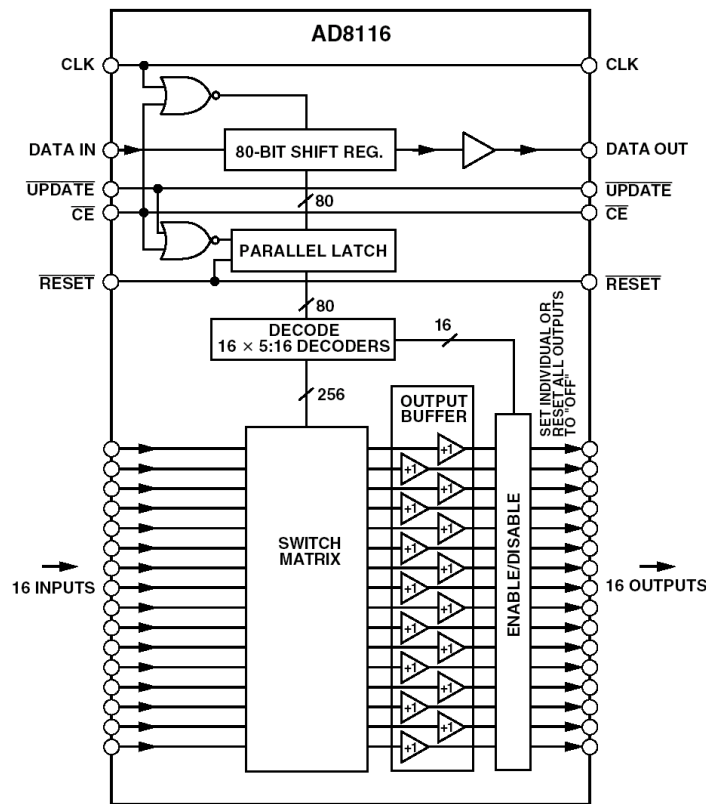

**Figure 5: AD8116 16x16 200-MHz Buffered Video Crosspoint Switch**

The [ADV3200/ADV3201](#) are  $32 \times 32$  analog crosspoint switch matrices. They feature a selectable sync-tip clamp input for ac-coupled applications and an on-screen display (OSD) insertion mux. With  $-48$  dB of crosstalk and  $-80$  dB isolation at 5 MHz, the ADV3200/ADV3201 are useful in many high density routing applications. The 0.1 dB flatness out to 60 MHz makes the ADV3200/ADV3201 ideal for composite video switching.

The 32 independent output buffers of the ADV3200/ADV3201 can be placed into a high impedance state for paralleling crosspoint outputs so that off-channels present minimal loading to an output bus if building a larger array. The part is available in gain of +1 (ADV3200) or +2 (ADV3201) for ease of use in back-terminated load applications. A single 5 V supply, dual  $\pm 2.5$  V supplies, or dual  $\pm 3.3$  V supplies ( $G = +2$ ) can be used while consuming only 250 mA of idle current with all outputs enabled. The channel switching is performed via a double buffered, serial digital control, which can accommodate daisy chaining of several devices.

The ADV3200/ADV3201 are packaged in a 176-lead exposed pad LQFP (24 mm  $\times$  24 mm) and are available over the extended industrial temperature range of  $-40^{\circ}\text{C}$  to  $+85^{\circ}\text{C}$ .

## DIGITAL CROSSPOINT SWITCHES

The [AD8152](#) is a 3.2-Gbps  $34 \times 34$  asynchronous digital crosspoint switch designed for high speed networking (see Figure 6). The device operates at data rates up to 3.2 Gbps per port, making it suitable for Sonet/SDH OC-48 with Forward Error Correction (FEC). The AD8152 has digitally programmable current mode outputs that can drive a variety of termination schemes and impedances while maintaining the correct voltage level and minimizing power consumption. The part operates with a supply voltage as low as +2.5 V, with excellent input sensitivity. The control interface is compatible with LVTTTL or CMOS/TTL.

As the lowest power solution of any comparable crosspoint switch, the AD8152 dissipates less than 2 W at 2.5-V supply with all I/Os active and does not require external heat sinks. The low jitter specification of less than 45 ps makes the AD8152 ideal for high speed networking systems. The AD8152's fully differential signal path reduces jitter and crosstalk while allowing the use of smaller single-ended voltage swings. It is offered in a 256-ball SBGA package that operates over the industrial temperature range of  $0^{\circ}\text{C}$  to  $+85^{\circ}\text{C}$ .

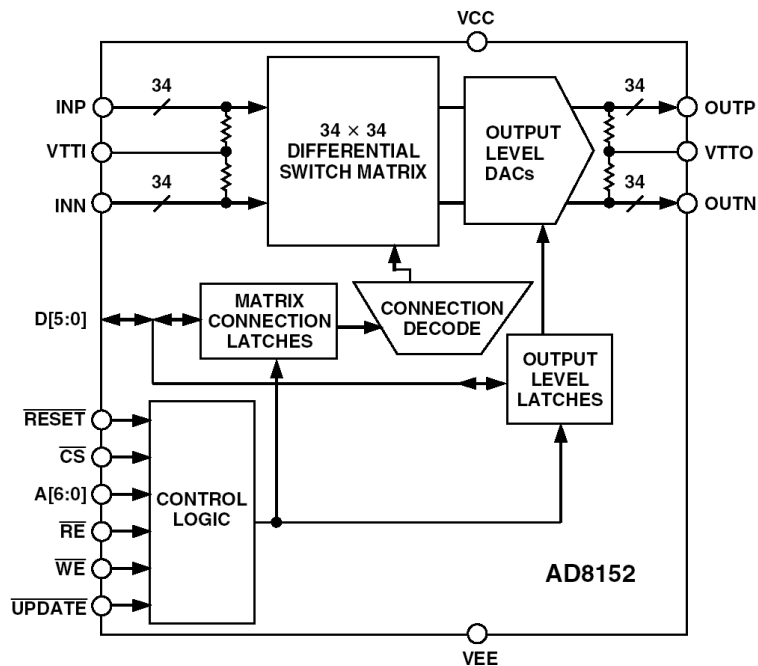

**Figure 6: AD8152 3.2-Gbps Asynchronous Digital Crosspoint Switch**

**REFERENCES:**

1. Hank Zumbahlen, *Basic Linear Design*, Analog Devices, 2006, ISBN: 0-915550-28-1. Also available as [\*Linear Circuit Design Handbook\*](#), Elsevier-Newnes, 2008, ISBN-10: 0750687037, ISBN-13: 978-0750687034. Chapter 7.
2. Walt Kester, [\*Analog-Digital Conversion\*](#), Analog Devices, 2004, ISBN 0-916550-27-3, Chapter 7. Also available as [\*The Data Conversion Handbook\*](#), Elsevier/Newnes, 2005, ISBN 0-7506-7841-0, Chapter 7.

Copyright 2009, Analog Devices, Inc. All rights reserved. Analog Devices assumes no responsibility for customer product design or the use or application of customers' products or for any infringements of patents or rights of others which may result from Analog Devices assistance. All trademarks and logos are property of their respective holders. Information furnished by Analog Devices applications and development tools engineers is believed to be accurate and reliable, however no responsibility is assumed by Analog Devices regarding technical accuracy and topicality of the content provided in Analog Devices Tutorials.