



TinyCalc™ User's Guide (Excel® 07 Version)

Introduction

TinyCalc™ is a Microsoft® Excel®-based calculator created to simplify the design of TinyBuck™-based regulators. TinyBuck™ products are integrated synchronous buck regulators with one high-side and one low-side MOSFET and a controller / driver integrated in one 5x6mm molded leadless package (MLP).

The last digit in the part number signifies the current rating of the product. This calculator covers designs with FAN2103, FAN2106, FAN2108, FAN2110, FAN21SV04, and FAN21SV06 regulators. Regulators with SV in the part numbers have a built-in 5V regulator.

This document describes how to configure Excel 07 so this calculator can work without errors. This guide explains how to use the TinyCalc™ calculator to choose external components for designs once the input and output conditions are provided.

Video Instructions

If you would prefer to watch an online video, click on the following link: [“TinyCalc Setup Video”](#)

Before Opening TinyCalc™

Add-in installation and Macro security selections must be set up before opening TinyCalc™.

Check for Installed Add-in(s)

1. Open a new (blank) Excel worksheet.
2. Click on the Windows icon at the top left.
3. This opens up a pop-up window (at right).
4. Click on the **Excel Options** button at the bottom of this dialog box which opens the Excel Options window.
5. Click on the **Add-Ins** tab on the left side of Excel Options window. This lists all the Add-ins available.
6. Click on the drop-down window next to **Manage:** at the left bottom, select **Excel Add-ins**, and then click on the **Go...** button next to it.
7. This opens the Add-Ins dialog box.

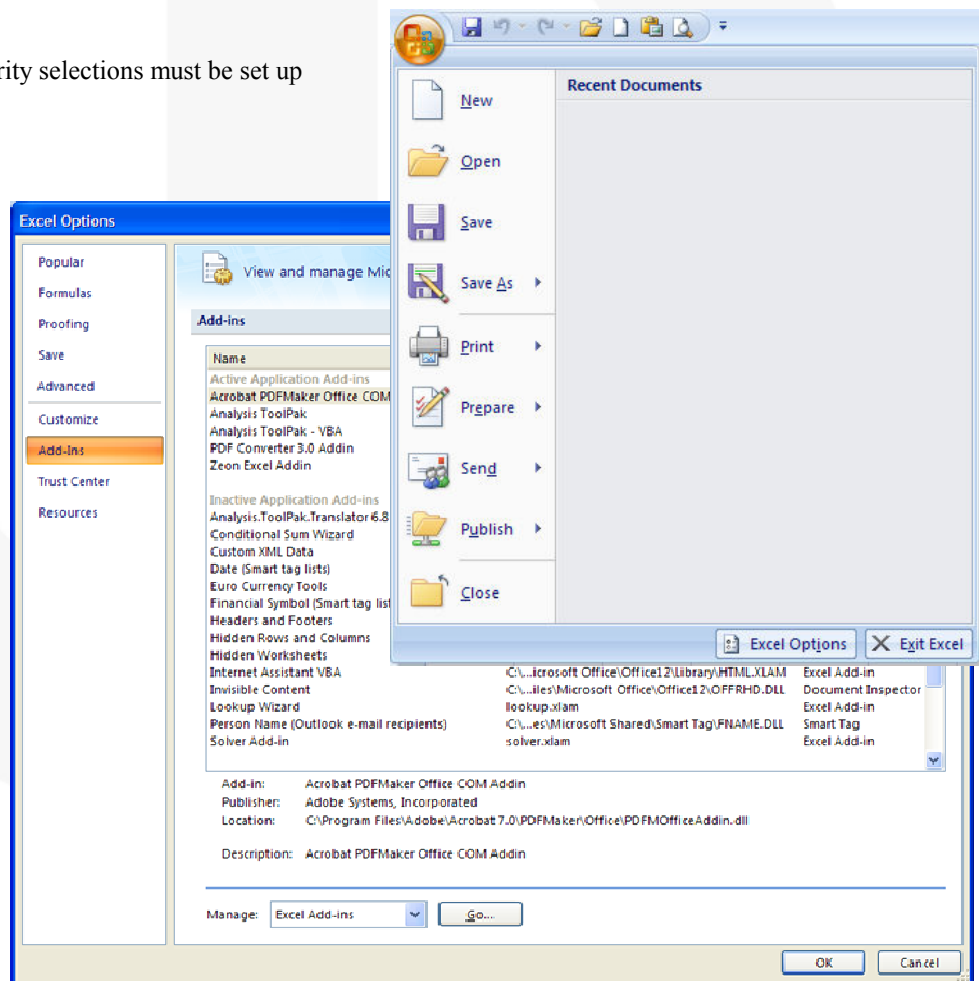

8. Select **Analysis Toolpak** and **Analysis Toolpak – VBA**. Disregard any other add-ins.
9. Click **OK** and return to the new worksheet.

Note: If these two add-ins aren't available in the Excel installation, it is necessary to install the complete version of Excel.

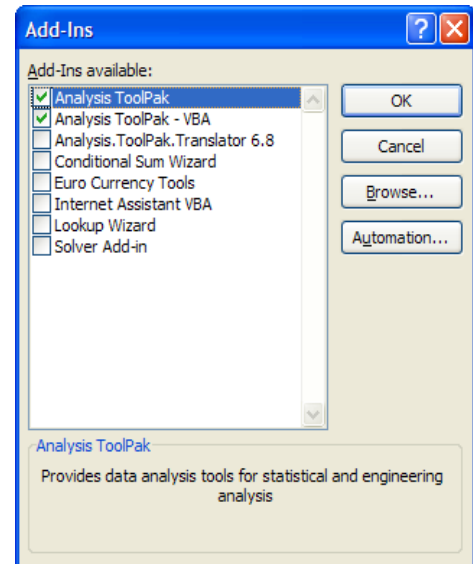

Set Macro Security to Medium

TinyCalc™ works by embedding calculations as macros. Excel must be able to run these macros for the application to function, but macros are considered a security risk. Therefore, to run the macros, it is necessary to set your security to medium (vs. high). With the new (blank) worksheet open, follow these steps to set the macro security:

1. Click the Windows icon located at the top left of the screen.

2. Click on the **Excel Options** button at the bottom right of the window.

3. Select **Trust Center** in the left side of Excel options window

4. Click on the **Trust Center Settings...** button at the right.

5. Select the **Macro Settings** in the left pane of the Trust Center window.

6. Select the option: **Enable all macros** (which opens all files with macros) **OR** **Disable all macros with notification** (which prompts each time a file with macros is opened).

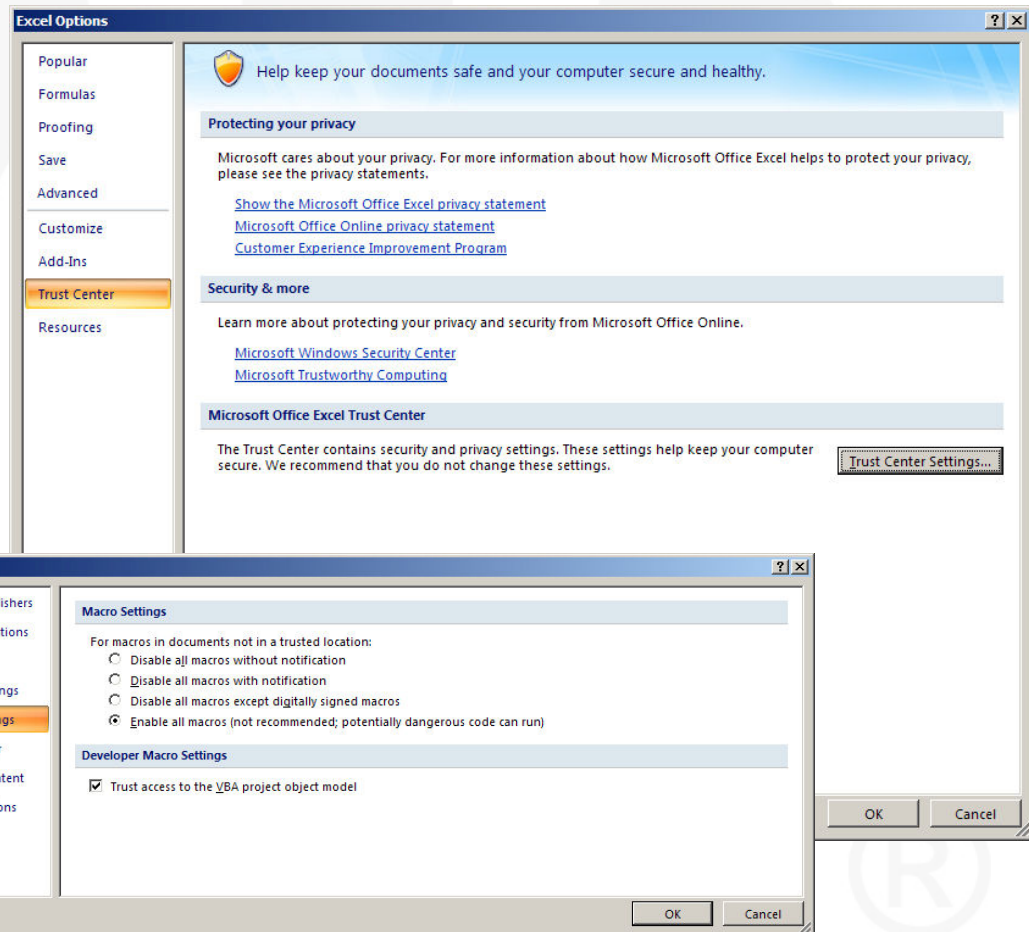

7. Click **OK** and click **OK** again on the last window open. This returns to the open blank sheet.
8. Close the blank worksheet.

Working with TinyCalc™

1. Close any open Excel workbooks or worksheets.
2. Open the TinyCalc™ file delivered with this user guide. (The file name might change based on the revision – go to the website to get the latest version of the calculator.)
3. If macros are enabled, the file opens without any warning. Skip to step 7.
4. If macros are disabled with notification, the file opens with a security warning.
5. Click on the **Options...** button.
6. Select the option **Trust all documents from this publisher** and click **OK**. This closes the security alert and allows the TinyCalc™ file to open.
7. When prompted to accept Fairchild's terms and conditions to use TinyCalc™, click the **I Agree** button.

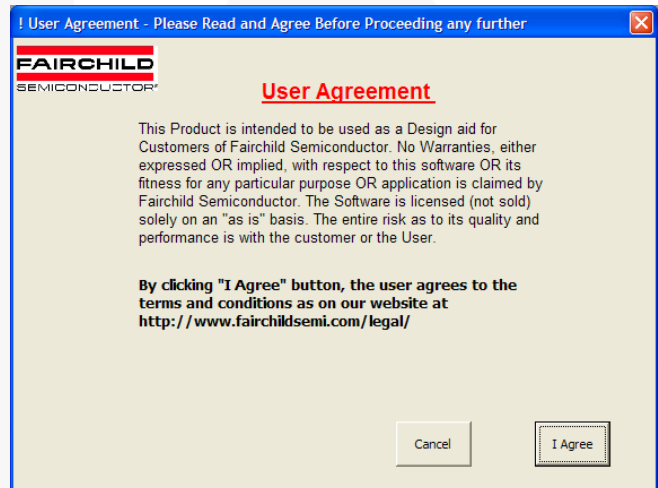
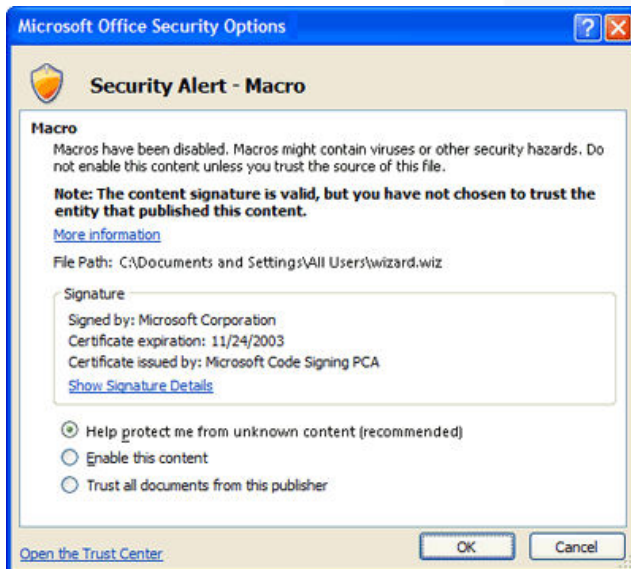
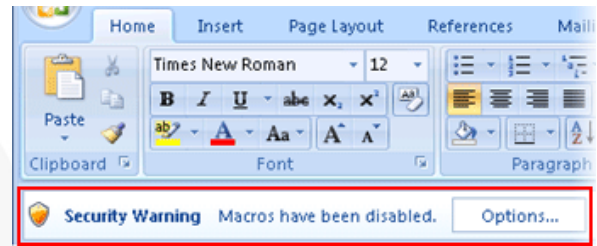

8. In the Select Regular dialog box, select the regulator for your circuit design from the drop-down list and click **OK**.

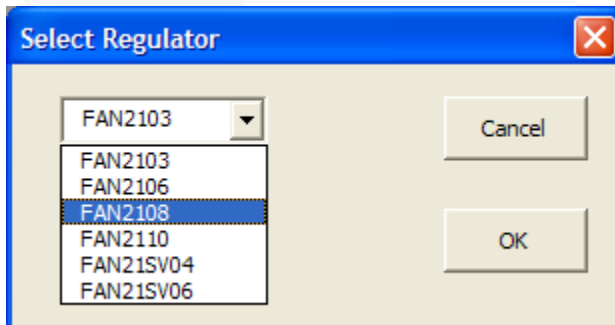

9. Click **OK** to confirm the selection.

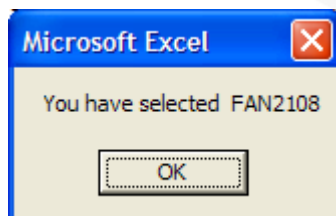

TinyCalc™ User Interface

The figure below is the “Front Page.” The numbers from 1 to 7 indicate the order of the steps involved in going through a design. Once you are familiar with this calculator, you can skip to steps as needed by clicking on the appropriate button.

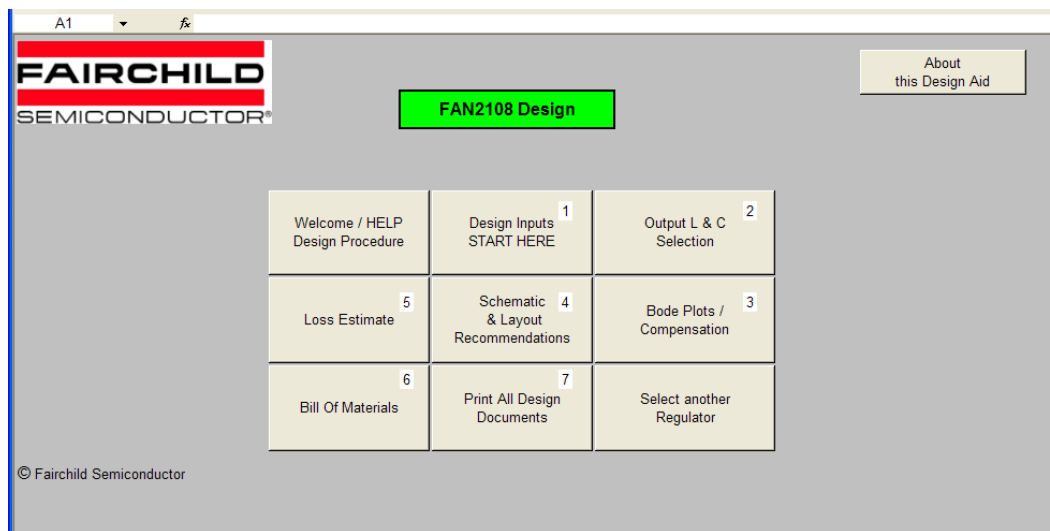

Clicking on the **Welcome / Help / Design Procedure** button opens the following dialog box. It is intended to provide first-time users a brief description of the steps. It is recommended that you read this page when you use the calculator for the first time. Click **OK** to return to the Front Page.

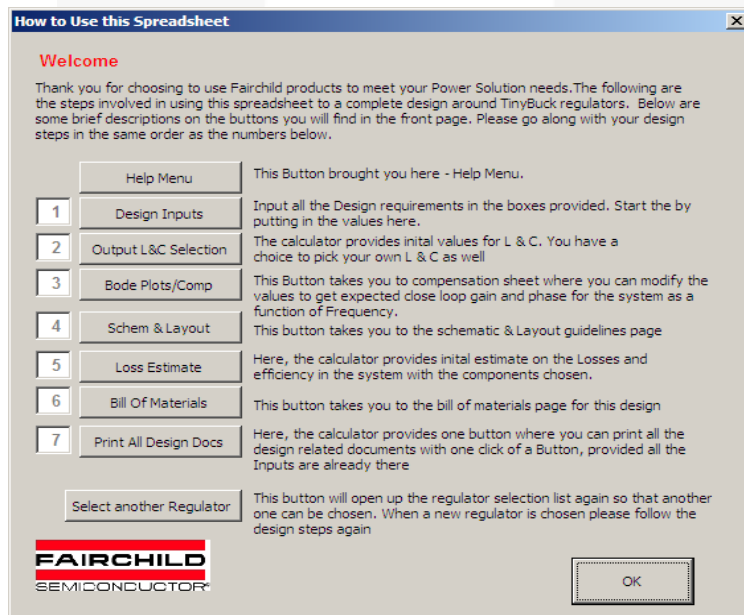

STEP 1 – Design Inputs



1. Click on the **Design Inputs / START HERE** button.

2. In the Input Parameters dialog box, enter the numbers for each of the design input variables.

Notes:

- a. Press the tab key to move to the next field.
 - b. If you enter a unsuitable value, an error message appears providing the appropriate range for the parameter. The control remains in the window until an acceptable value is entered. The acceptable range is based on the specifications of the regulator selected.
3. After all the values are entered, click **OK**. If all the variables are accepted as valid inputs, the calculator closes and returns to the Front page.

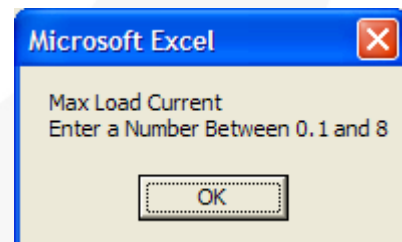

STEP 2 – Output L&C Section



1. Click on the **Output L&C Section** button to open the Select the Right Inductor and Capacitor dialog box. The top two boxes show suggested inductor and capacitor values.

 A screenshot of a software dialog box titled "Select the Right Inductor and Capacitor". The dialog box has a blue title bar with a close button (X) in the top right corner. The main area has a light beige background. At the top left is the Fairchild Semiconductor logo. The title "Suggested Inductor and Capacitor Values based on Parameter Inputs" is centered. Below the title, there are two input fields: "Suggested Inductor Value" with the value "3.63" and unit "uH", and "Suggested Minimum Capacitor Value" with the value "60.02" and unit "uF". A blue instruction text reads: "Please choose your Preferred Inductor and Capacitor Values including their ESRs (DCRs) below". Below this, there are several input fields arranged in two columns. The left column includes: "Inductance" (3.3 uH), "Inductor DCR" (10 mOhm), and "Ripple Current with Chosen Inductor(pk-pk)" (0.99 Amps). The right column includes: "Bulk Capacitance" (0 uF), "Bulk Cap ESR" (0 mOhm), "Bulk Cap ESL" (0 nH), "Net Ceramic Cap Value" (88 uF), and "Net Ceramic Cap ESR" (2 mOhm). There are "Help" and "OK" buttons on the right side of the dialog box.

2. Enter data for the inductor and capacitors (with combinations) for your design.

Note: If either of the ceramic OR electrolytic capacitors (bulk) is used alone, put zero (0) for parameters of the capacitor not used. Use only numbers in these boxes.

3. After all the values are entered, press **OK** and return to the Front page.

STEP 3 – Bode Plots / Compensation

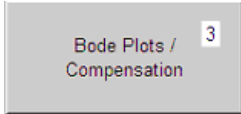

1. Click on the **Bode Plots / Compensation** button.
2. This opens a worksheet where you can select the compensation components required to close the control loop and ensure stable operation of the converter. Before you are given control on this sheet the first time, a message appears informing you that changes affect the bill of materials. This is for your information only.

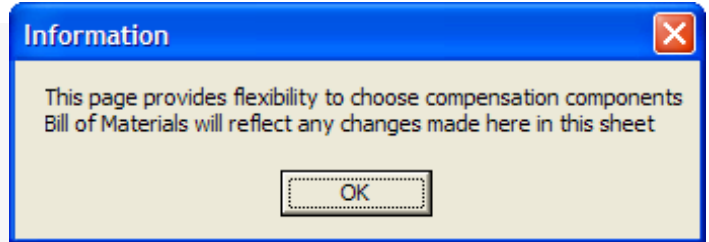

3. Press **OK** to close this window and begin using the worksheet.

There are five columns in this worksheet, with rows 2 and 3 containing numbers. The second column is a set of recommended values corresponding to the component designators in the pictures below the two rows. The third column is where you can modify the numbers and see how the component values change phase margin.

Parameter / Component Values	Recommended Starter Values	User Chosen Values	Units	Comments	
Loop Bandwidth	50	50	KHz.	Choose a different crossover frequency if needed. Default value is FSW/10. Choose a number between FSW/12 & FSW/8. Suggested component values in column B change as this number changes.	Go to Front Page
C1	47	47	pF	Suggested component values for C1-C3, R1-R3, Rbias & Ramp are in column B. They can be changed to suit application needs in column C. Proceed to "Bode Plots" after making changes.	Go To Schematic
C2	3,300	3,300	pF		Go To Bode Plots
C3	5,600	5,600	pF		Print this page
R1	2,490	2,490	KΩ		Copy Data & Pictures
R2	3.83	3.830	KΩ		
R3	0.029	0.029	KΩ		
Rbias	2,000	2,000	KΩ		
Rramp	169	169	KΩ		
Expected Phase Margin		73	Degrees	With Vin(max)	
Vout	1.796	1.796	V	Expected Vout	

There are buttons to the right to help you navigate from one sheet to other.

Go to Front Page returns you to the Front Page.

Go to Schematic accesses the typical application schematic for the part (same as step 4 from the Front Page).

Go to Bode Plots accesses graphs based on your component selections and values (*see next page*).

Print this Page sends the current sheet to the printer of your choice.

Copy Data & Pictures saves this data to the Windows clipboard in a picture format for you to paste into any other Microsoft document.

The Bode Plots page displays plots for full load at minimum and maximum input voltage conditions.

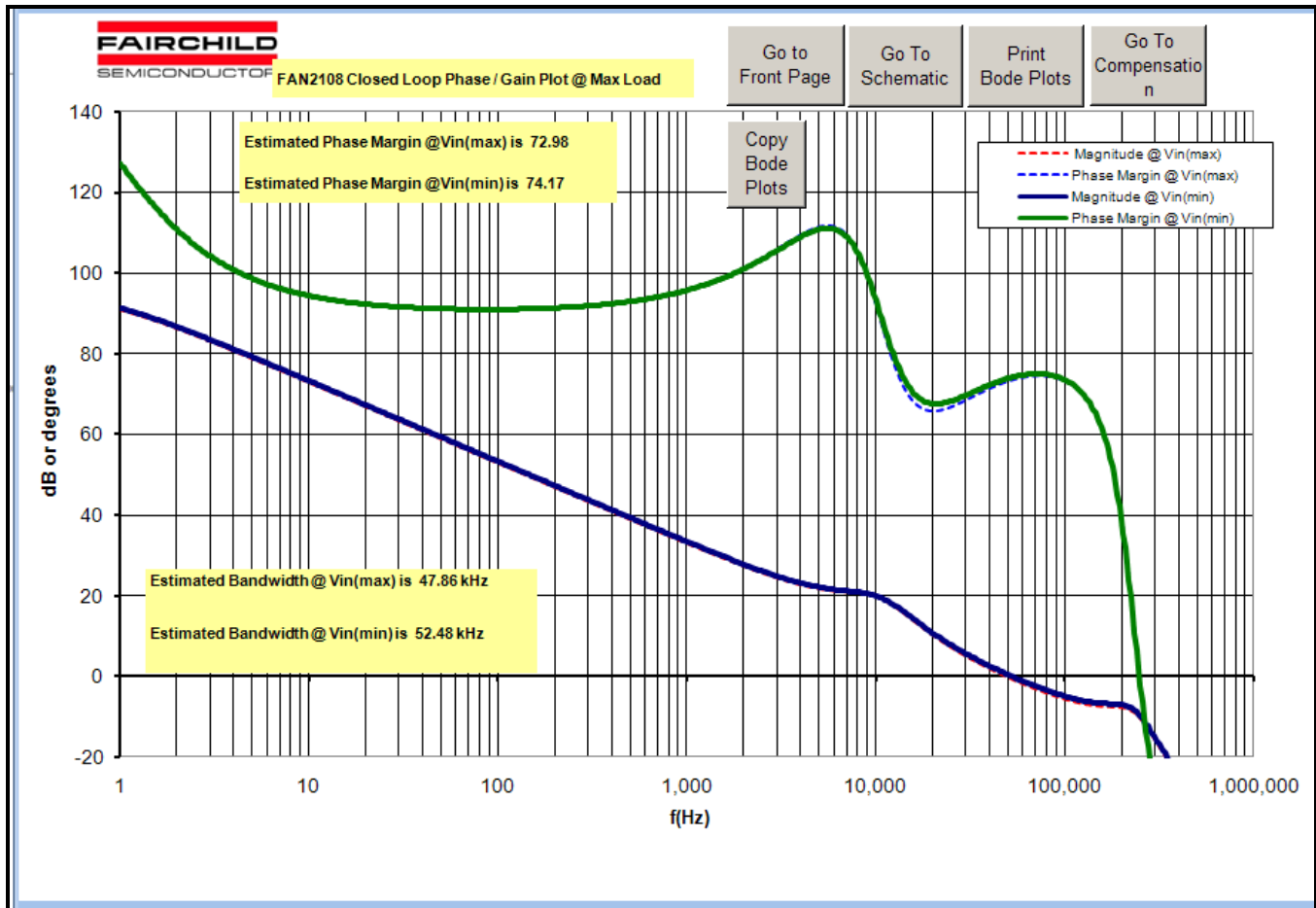

There are text boxes that display the crossover frequency (bandwidth) and the phase margin for this design. Typically, it is a good idea to have greater than 60° of phase margin and bandwidth less than one fifth ($1/5$) of the switching frequency. Each time you return to this page, the new plot is based on the components selected.

There are buttons along the top to help you navigate from one sheet to other.

Go to Front Page returns you to the Front Page.

Go to Schematic accesses the typical application schematic for the part (same as step 4 from the Front Page).

Go to Compensation allows you to change or adjust any of the component values.

Print Bode Plots sends the current sheet to the printer of your choice.

Copy Bode Plots saves the plot to the Windows clipboard in a picture format for you to paste into any other Microsoft document.

STEP 4 – Schematics & Layout Recommendations

Schematic & Layout Recommendations 4

Click on **Schematics & Layout Recommendations** button. The typical application diagram that appears changes based on the controller chosen.

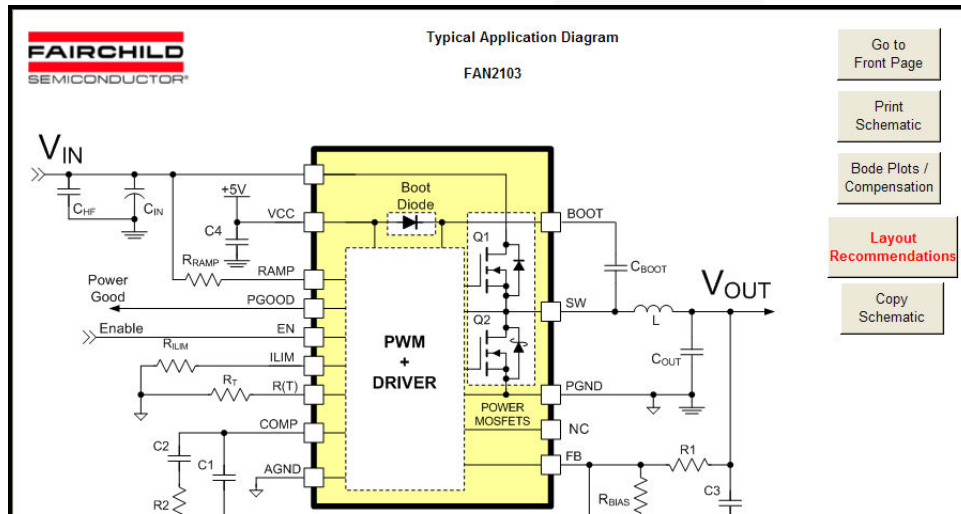

There are buttons at the right to help you navigate from one sheet to other.

Go to Front Page returns you to the Front Page.

Print Schematic sends the current diagram to the printer of your choice. All the component designators in the Bill of Material sheet (Step 6) refer to this schematic.

Bode Plots / Compensation allows you to change or adjust any of the component values.

Layout Recommendations accesses general recommendation on how to layout switching regulators and provides a copy of the evaluation board layout.

Copy Schematic saves the diagram to the Windows clipboard in a picture format for you to paste into any other Microsoft document.

STEP 5 –Loss Estimate

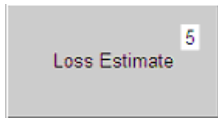

Click on the **Loss Estimate** button. The calculator estimates efficiency and losses at minimum and maximum input voltage conditions with the load current as a variable at room temperature in chart form.

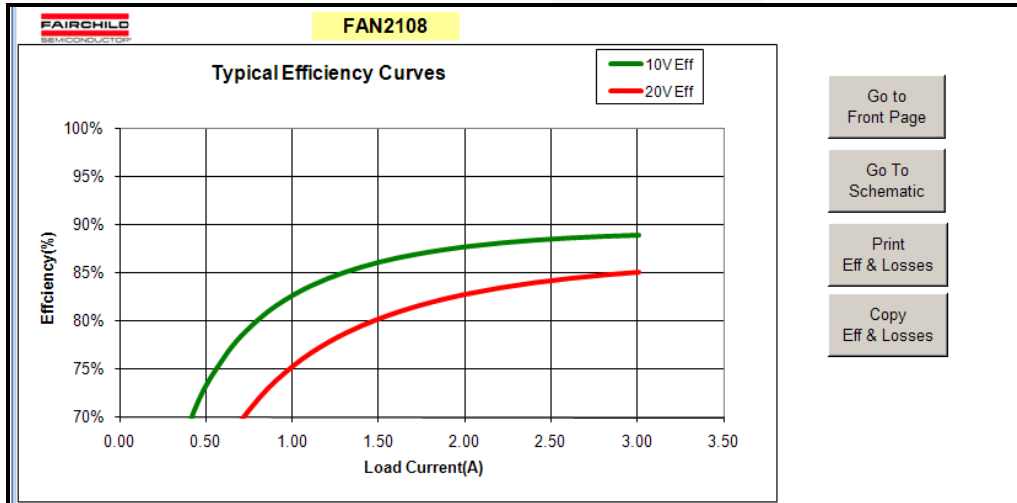

There are buttons at the right to help you navigate from one sheet to other.

Go to Front Page returns you to the Front Page.

Go to Schematic accesses the typical application schematic for the part (same as step 4 from the Front Page).

Print Eff & Losses sends the current charts to the printer of your choice.

Copy Eff & Losses saves the charts to the Windows clipboard in a picture format for you to paste into any other Microsoft document.

STEP 6 – Bill of Materials



1. Click on **Bill of Materials** button.
2. A dialog box that appears to make sure that you don't jump into this section without entering right values for the inductor and output capacitor. Press **OK** to proceed to the Bill of Materials worksheet or **Cancel** to return to the Front Page.

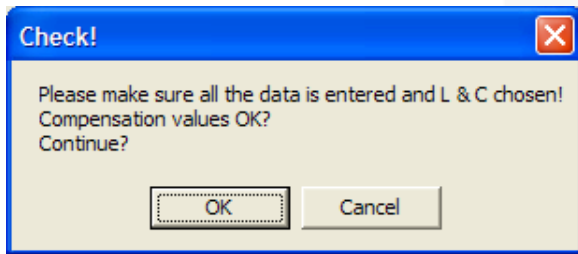

This sheet provides all the component values needed to build the design according to your selections and entered values. This sheet includes any changes made in the “compensation” components as well as the inductor and output capacitors. There are a few component manufacturers links for capacitors and inductors to help you find the right parts.

FAIRCHILD SEMICONDUCTOR®				Go to Schematic	Print BOM	Go to Front Page	Copy BOM
REF		Units	QTY	DESCRIPTION	Manufacturer Links		
U1	FAN2108	IC	1	IC, FAN2108, MLP5x6	Fairchild Semiconductor		
C1	47.00	pF	1	5% NPO	Generic		
C2	3.30	nF	1	10% X7R	Generic		
C3	5.60	nF	1	10% X7R	Generic		
C4	1	uF	1	1.0uf, 10V, X5R	Generic		
C6	TBD	pF	1	10% X7R - See Note Below on Snubbers	Generic		
Cboot	0.1	uF	1	0.1uf, 16V, X7R	Generic		
Cen	3.3	nF	1	10% X7R -When delayed auto-restart is needed	Generic		
Chf	3.3	nF	1	3.3nf, 50V, X7R	Generic		
Cin	User Select	uF	1	Choose a Capacitor with minimum RMS Current rating of 1 Amps	United Chemi-con	Panasonic	
Cout (Bulk)	0	uF	1	Net Bulk output Capacitance (Electrolytic)	United Chemi-con	Panasonic	
Cout (Ceramic)	88	uF	1	Net Ceramic Capacitors on the output	AVX	Murata	
L	3.30	uH	1	Output Inductor, with at least 3.49 A Current rating	Inter-Technical	Cooper-Bussman	Sumida
R _{PULL}	10	KΩ	1	PGOOD pull-up to +Vcc.	Generic		
R1	2.49	KΩ	1	1%	Generic		
R2	3.83	KΩ	1	1%	Generic		
R3	28.70	Ω	1	5%	Generic		
R6	TBD	Ω	1	5%, 1206 - See Note Below on Snubbers	Generic		
Rbias	2.00	KΩ	1	1%	Generic		
Rlim	200.00	KΩ	1	1% (only if less than default OCP)	Generic		
Rramp	169.00	KΩ	1	1%	Generic		
Rt	28.70	KΩ	1	1%	Generic		

There are buttons along the top to help you navigate from one sheet to other.

Go to Schematic accesses the typical application schematic for the part (same as step 4 from the Front Page).

Print BOM sends the current worksheet to the printer of your choice.

Go to Front Page returns you to the Front Page.

Copy BOM saves the worksheet view to the Windows clipboard in a picture format for you to paste into any other Microsoft document.

STEP 7 – Print All Design Documents

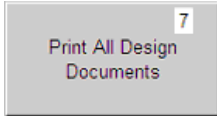

1. Click on the **Print All Design Documents** button.
2. A dialog box that appears to make sure that you don't jump into this section without entering right values for the inductor and output capacitor. Press **OK** to proceed to print preview or **Cancel** to return to the Front Page.

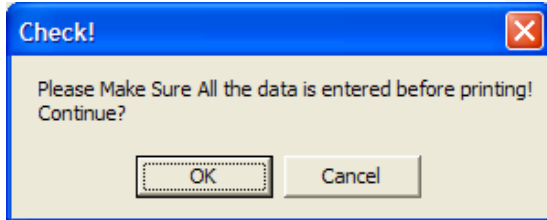

This enables you to print all the design documents once. This feature is helpful if you have this design saved and you want to print the documents at all later time. This accesses the standard M\$Excel print preview functionality.

3. Click **Print...** to select the printer and the number of copies to print.

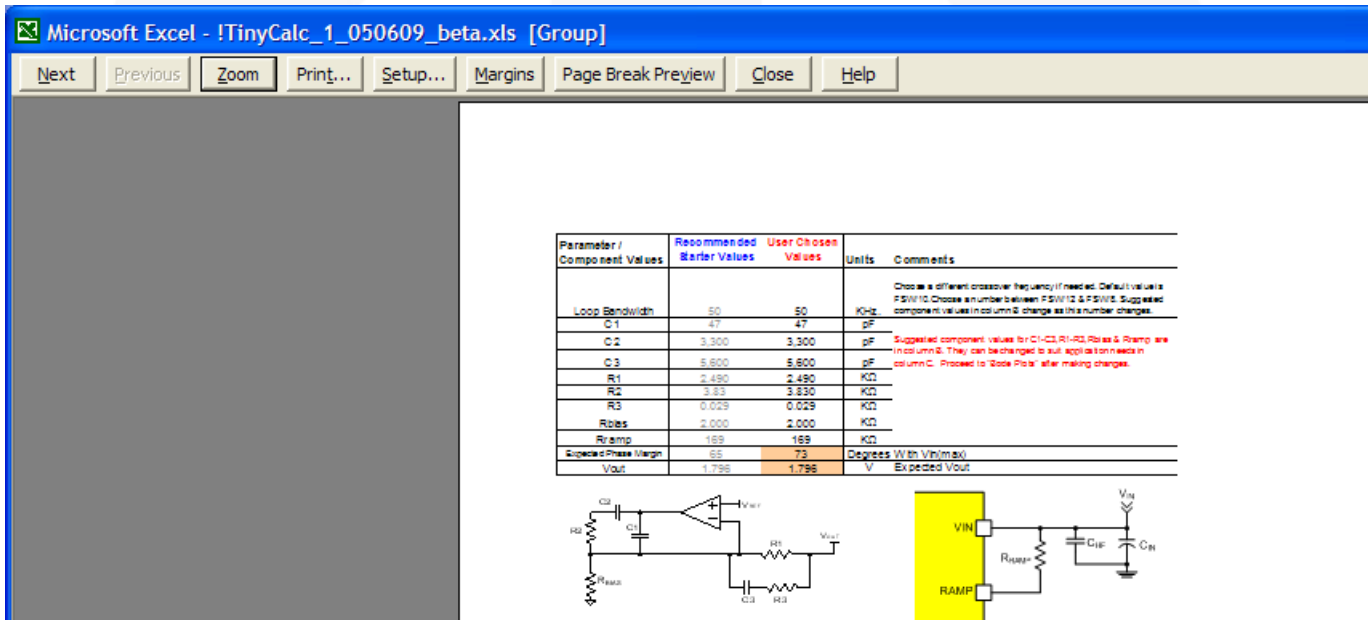

After printing, the control returns to the Front Page.

Select Another Regulator



1. Click the **Select Another Regulator** Button to repeat the process with a new regulator (*see STEP 1*).

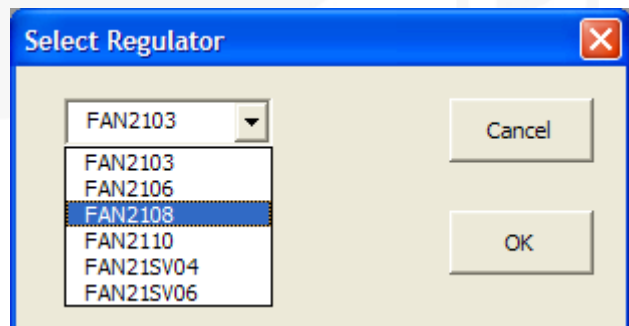

Design Complete!

Related Datasheets

[FAN2103 — TinyBuck™ 3A, 24V Input Integrated Synchronous Buck Regulator](#)

[FAN2106 — TinyBuck™ 6A, 24V Input Integrated Synchronous Buck Regulator](#)

[FAN2108 — TinyBuck™ 3-24V Input, 8A, High-Efficiency, Integrated Synchronous Buck Regulator](#)

[FAN2110 — TinyBuck™ 3-24V Input, 10A, High-Efficiency, Integrated Synchronous Buck Regulator](#)

[FAN21SV04 — TinyBuck™ 4A, 24V Single-Input Integrated Synchronous Buck Regulator](#)

[FAN21SV06 — TinyBuck™ 6A, 24V Input, Single Supply, Integrated Synchronous Buck Regulator](#)

[TinyCalc™ Calculator for the Design of TinyBuck™-Based Regulators](#)

Notes:

Every effort has been made to ensure that TinyCalc is accurate and reliable; however, if a command throws a “**Run-Time Error**,” closing and opening it resolves the issue.

Excel users who have been using Excel 97 through Excel 2003 who upgrade to Excel 2007 or 2010 may find the new ribbon system confusing. If this is the case, Microsoft® has released a free workbook that maps Excel 97-2003 commands to the ribbon: [Excel Ribbon Mapping Workbook](#) that may be useful.

DISCLAIMER

FAIRCHILD SEMICONDUCTOR RESERVES THE RIGHT TO MAKE CHANGES WITHOUT FURTHER NOTICE TO ANY PRODUCTS HEREIN TO IMPROVE RELIABILITY, FUNCTION, OR DESIGN. FAIRCHILD DOES NOT ASSUME ANY LIABILITY ARISING OUT OF THE APPLICATION OR USE OF ANY PRODUCT OR CIRCUIT DESCRIBED HEREIN; NEITHER DOES IT CONVEY ANY LICENSE UNDER ITS PATENT RIGHTS, NOR THE RIGHTS OF OTHERS.

LIFE SUPPORT POLICY

FAIRCHILD'S PRODUCTS ARE NOT AUTHORIZED FOR USE AS CRITICAL COMPONENTS IN LIFE SUPPORT DEVICES OR SYSTEMS WITHOUT THE EXPRESS WRITTEN APPROVAL OF THE PRESIDENT OF FAIRCHILD SEMICONDUCTOR CORPORATION.

As used herein:

1. Life support devices or systems are devices or systems which, (a) are intended for surgical implant into the body, or (b) support or sustain life, or (c) whose failure to perform when properly used in accordance with instructions for use provided in the labeling, can be reasonably expected to result in significant injury to the user.
2. A critical component is any component of a life support device or system whose failure to perform can be reasonably expected to cause the failure of the life support device or system, or to affect its safety or effectiveness.