

## Upgrade Your Microcontroller ADC to True 12-Bit Performance

Design Note DN463

by Guy Hoover

### Introduction

Many 8-bit and 16-bit microcontrollers feature 10-bit internal ADCs. A few include 12-bit ADCs, but these often have poor or nonexistent AC specifications, and certainly lack the performance to meet the needs of an increasing number of applications. The LTC®2366 and its slower speed versions offer a high performance alternative, as shown in the AC specifications in Table 1. Compare these guaranteed specifications with the ADC built into your current microcontroller.

This family's DC specifications are equally impressive. INL and DNL are guaranteed to be less than  $\pm 1$ LSB. Operating from a single 2.5V, 3V or 3.3V supply, the current draw on these parts is a maximum of 4mA during a conversion. This can be reduced to less than  $1\mu\text{A}$  by placing the part into SLEEP mode during periods of inactivity, which greatly reduces the average supply current at lower sample rates.

These ADCs are available in tiny 6-lead and 8-lead TSOT-23 packages. The 8-lead devices have adjustable  $V_{\text{REF}}$  and  $\text{OV}_{\text{DD}}$  pins. The adjustable  $V_{\text{REF}}$  pin allows the input span to be reduced to 1.4V. This, combined with the high ADC input impedance, can eliminate the need for gain or buffer stages in many applications. The  $\text{OV}_{\text{DD}}$  pin, which controls the digital output level, can be adjusted from 1V to 3.6V, simplifying communication with different logic families. For applications that do not require an adjustable reference or adjustable output levels, the 6-lead device with  $V_{\text{REF}} = \text{OV}_{\text{DD}} = V_{\text{DD}}$  should suffice.

The SPI interface requires only three wires to communicate with the microcontroller, keeping the overall solution size small in low power, high speed applications.

LT, LT, LTC and LTM are registered trademarks of Linear Technology Corporation. All other trademarks are the property of their respective owners.

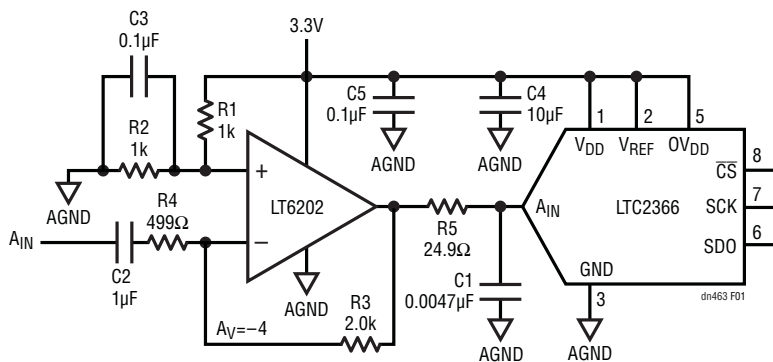

Figure 1. Single Supply AC-Coupled Amplifier Level Shifts Input for Maximum Dynamic Range

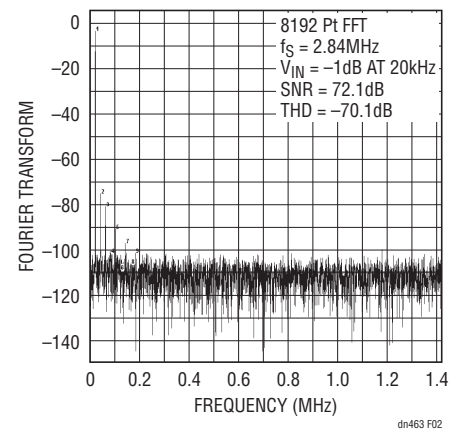

Figure 2. FFT Shows Low Noise and Distortion of Figure 1 Circuit

## Application Circuits

Figure 1 shows a single supply AC-coupled amplifier driving the LTC2366. This circuit is useful in applications where the sensor output level is too low to achieve full SNR performance from the ADC. The output of the LT<sup>®</sup>6202 swings rail-to-rail. This feature maximizes the circuit's dynamic range when the op amp output is level shifted to the center of the ADC's swing. The FFT of Figure 2 demonstrates the low noise and distortion of this circuit.

In Figure 3, a single supply DC amplifier with a programmable gain of 0 to 4096 drives the LTC2360. With a maximum offset of 10 $\mu$ V and a DC to 10Hz noise of 2.5 $\mu$ V<sub>P-P</sub>,

the LTC6915 is a good choice for high gain applications. This circuit is useful for very low level signals or for applications with a wide range of input levels.

## Conclusion

The 12-bit ADCs in the LTC236x family guarantee AC specifications that most built-in microcontroller ADCs cannot meet, thus improving performance when used in place of on-chip ADCs. The LTC236x family is easily interfaced to most microcontrollers via its SPI interface. A wide range of sample rates, an external reference pin and a separate OV<sub>DD</sub> pin provide additional flexibility.

**Table 1. LTC236x ADC Family AC Specifications**

PART NUMBER	SAMPLE RATE	SINAD	SNR	THD	FULL LINEAR BANDWIDTH
LTC2366	3Msps	68dB (Min)	69dB (Min)	-72dB (Max)	2.5MHz (Typ)
LTC2365	1Msps	68dB (Min)	70dB (Min)	-72dB (Max)	2.0MHz (Typ)
LTC2362	500ksps	72dB (Typ)	73dB (Typ)	-85dB (Typ)	1.0MHz (Typ)
LTC2361	250ksps	72dB (Typ)	73dB (Typ)	-85dB (Typ)	1.0MHz (Typ)
LTC2360	100ksps	72dB (Typ)	73dB (Typ)	-85dB (Typ)	1.0MHz (Typ)

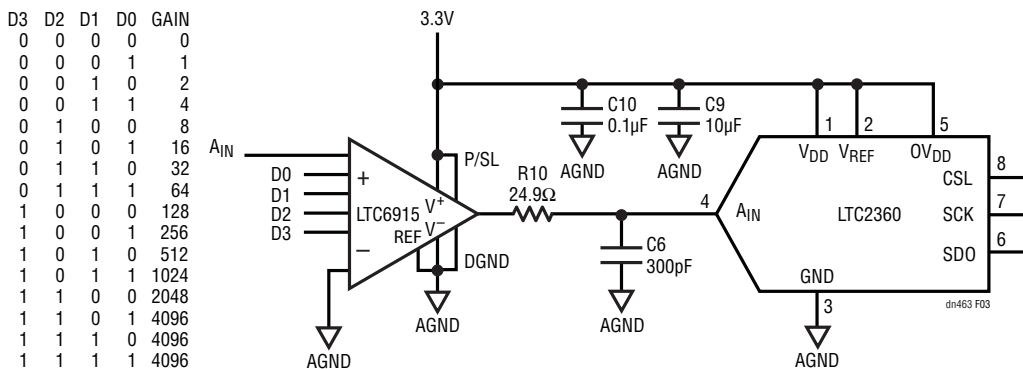

**Figure 3. Single Supply DC Amplifier Provides Programmable Gain from 0 to 4096**

Data Sheet Download

[www.linear.com](http://www.linear.com)

For applications help,  
call (408) 432-1900, Ext. 2602

Linear Technology Corporation  
1630 McCarthy Blvd., Milpitas, CA 95035-7417  
(408) 432-1900 • FAX: (408) 434-0507 • [www.linear.com](http://www.linear.com)

dn463 LT/TP 0409 155K • PRINTED IN THE USA

**www.BDTIC.com/Linear**

**LINEAR**  
TECHNOLOGY

© LINEAR TECHNOLOGY CORPORATION 2009