

# DESIGN NOTES

## A Precision Active Filter Block with Repeatable Performance to 10MHz – Design Note 324

Philip Karantzalis

### Introduction

The increasing speeds and dynamic ranges of modern communication and control systems make for complex filter requirements that have been, until now, a challenge to satisfy. Signal converters with high sampling rates can alleviate the need for selective filters, but even so, some sort of band limiting is still required. Some wireless systems face yet another problem. Even though the use of oversampling converters has significantly simplified filtering, unexpected signals from neighboring systems can intrude on a converter's allowed bandwidth.

The LT<sup>®</sup>1568 requires only a few external components to satisfy complex filtering requirements, including band rejection. An important feature to note is that the performance of the LT1568 is precisely repeatable from device-to-device, making it possible to manufacture filters in volume without the need for costly production trimming.

### Device Description

The LT1568 is a dual second order matched building block which is useful in a variety of ways for different applications. Each individual filter block uses two very low noise ( $1.5\text{nV}/\sqrt{\text{Hz}}$  input voltage noise) operational amplifiers

and an inverter op amp output (useful in applications requiring differential outputs or an output with phase reversal).

The LT1568, with a few passive components, can be used to design various filter functions (lowpass, bandpass, highpass, notch or allpass). One of the features of this device is its repeatable AC performance from part-to-part. This is achieved by trimming all the internal capacitors to a better than 1% tolerance and by trimming the gain bandwidth product (GBW) of all the internal op amps. Thus, any small error caused by the finite speed of the LT1568 active circuitry is highly predictable from part-to-part.

### Application Examples

The LT1568 is extremely versatile due in part to its generic internal architecture. The values of the external resistors for a few classical filter responses are given in the LT1568 data sheet. The resistor values for a wider selection of filter responses can be determined by using an LT1568 Design Guide found on [www.linear.com](http://www.linear.com). The following examples show two LT1568 filter circuits that are implemented using simple design equations.

LT, LTC and LT are registered trademarks of Linear Technology Corporation.

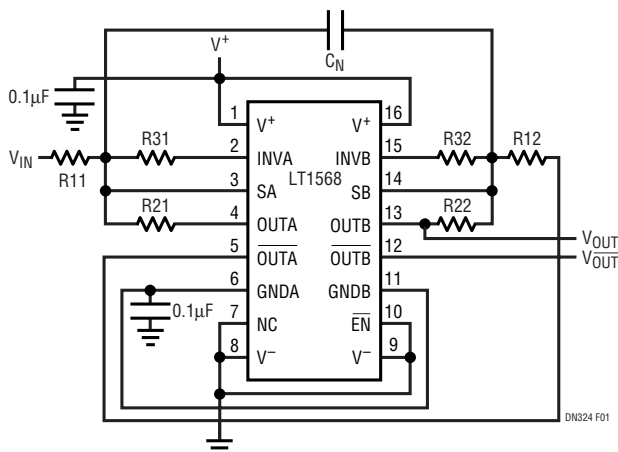

Figure 1. A 4th Order Elliptic Lowpass Filter Circuit (Single Supply Operation)

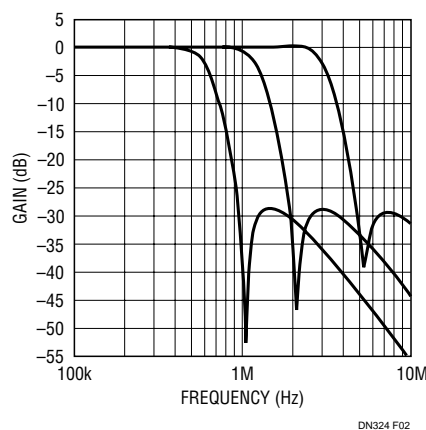

Figure 2. Amplitude Response of Figure 1 Circuit for Cutoff Frequencies of 500kHz, 1MHz and 2.5MHz

## A 4th Order Elliptic Lowpass Filter

The unique architecture of the LT1568 allows the addition of a notch by simply adding an external capacitor between the summing node of the first stage (SA) and the summing node of the second stage (SB), as shown in Figure 1. Capacitor  $C_N$  and resistor R12 are the only external passive components affecting the accuracy and repeatability of the notch frequency. A 4th order  $\pm 0.25$ dB passband lowpass filter with one stopband notch and equal value resistors is designed as follows:

$$C_N = 82\text{pF};$$

$$R11 = R21 = R31 = R12 = R22 = R32 = 806\Omega$$

( $1\text{MHz}/f_{\text{CUTOFF}}$ );  $f_{\text{CUTOFF}}$  is the  $\pm 0.25$ dB passband

This expression is useful for cutoff frequencies up to 2.5MHz. Cutoff frequencies of 500kHz, 1MHz and 2.5MHz are shown in Figure 2.

## A 4th Order Bandpass Filter

The LT1568 makes it possible to produce accurate selective bandpass filters in volume which until now has been a difficult task. This is another result of its unique topology and carefully trimmed internal components. The LT1568 also makes the basic design of a bandpass filter extremely easy. Simply replace the input resistor of an LT1568 2nd order lowpass section with a capacitor ( $C_{IN}$ ) and the lowpass section transforms into a second order bandpass filter. A fourth order bandpass circuit is shown in Figure 3. The center frequency of the bandpass function depends on the product  $R2 \cdot R3 \cdot C1 \cdot C2$  ( $C1$  and  $C2$  are the internal

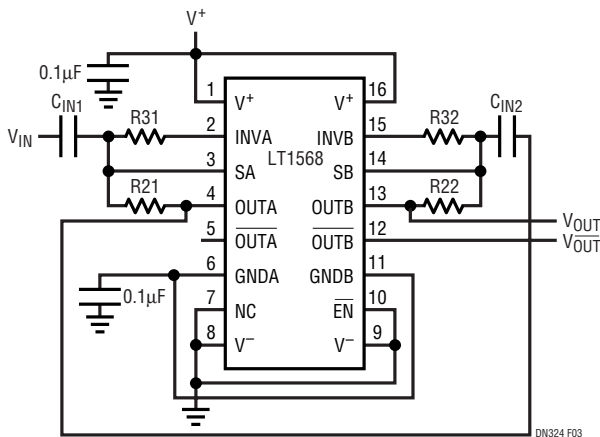

Figure 3. A 4th Order Bandpass Filter Circuit (Single Supply Operation)

LT1568 capacitors) but it also depends on the ratio of  $C_{IN}/C2$ . If the ratio of  $C_{IN}/C2$  is kept small ( $C_{IN} \leq C2$ ), then a five percent variation in the value of  $C_{IN}$  keeps the bandpass filter's center frequency variation to around one percent or less.

The component values for a 4th order bandpass filter with unity gain at the center frequency and a  $-3$ dB passband equal to  $f_{\text{CENTER}}/3.5$  are designed as follows:

$$C_{IN1} = C_{IN2} = 68\text{pF};$$

$$R21 = R31 = R22 = R32 = [(268 \cdot 10^9)/(3.4 \cdot f_{\text{CENTER}}^2 + 250 \cdot 10^3 \cdot f_{\text{CENTER}})]\Omega$$

where  $f_{\text{CENTER}}$  is the center frequency in kHz. This expression is useful for cutoff frequencies up to 7MHz.

Figure 4 shows the response for a 1MHz bandpass filter.

## Conclusion

The LT1568 is the basis for analog filter designs of unprecedented predictability and repeatability. Its unique topology and precision trimmed active and passive components facilitate the implementation of low cost filters in the production of high frequency circuits and systems. The LT1568 is useful as a simple dual matched second or third order lowpass filter in I/Q applications, or with an external five-percent tolerance capacitor, the LT1568 can be used to build selective fourth order elliptic lowpass filters, accurate dual second order or single fourth order bandpass filters.

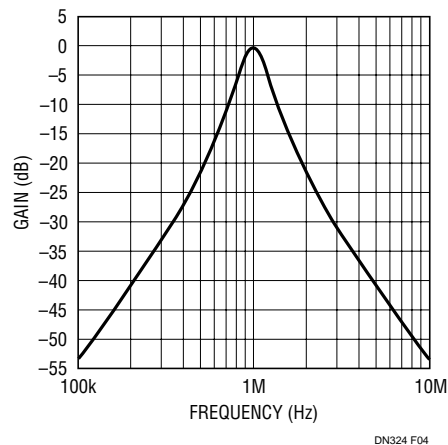

Figure 4. Amplitude Response of Figure 3 Circuit for 1MHz Center Frequency

### Data Sheet Download

<http://www.linear.com/go/dnLT1568>

For applications help,  
call (408) 432-1900, Ext. 2156