

# DESIGN NOTES

## Video Signal Distribution Using Low Supply Voltage Amplifiers

Design Note 327

Jon Munson

### Introduction

Video designs are often pressed to operate on the lowest possible rail voltages—a simple result of the trend towards lower voltage logic and the advantages of sharing supply potentials wherever possible. Video designs are further complicated by the need to accommodate the dynamic offset variation inherent in AC-coupled designs as picture content varies. Traditional op amps require relatively large amounts of output-swing headroom and are therefore impractical for AC coupling at even 5V. Linear Technology offers a new family of video op amps which addresses these issues and offers the ability to operate down to 3.3V in most instances. This family includes the LT<sup>®</sup>6205 (single), LT6206 (dual), LT6207 (quad), LT6550 (triple, fixed gain of 2) and LT6551 (quad, fixed gain of 2).

### Video Signal Characteristics

To determine the minimum video amplifier supply voltage, we must first examine the nature of the signal. Composite video is the most commonly used signal in broadcast-grade products and combines Luma (or luminance, the intensity information), Chroma (the colorimetry information) and Sync (vertical and horizontal raster timing) elements into a single signal, NTSC and PAL being the common formats.

Typical video waveforms are specified to have a nominal 1.0V<sub>P-P</sub> amplitude, as shown in Figure 1. The lower 0.3V is reserved for sync tips that carry timing information. The black level (zero intensity) of the waveform is at (or set up slightly above) this upper limit of the sync information. Waveform content above the black level is intensity information, with peak brightness represented at the maximum signal level. The sync potential represents blacker-than-black intensity, so scan retrace activity is invisible on a CRT. In the case of composite video, the modulated color subcarrier is superimposed on the waveform, but the dynamics generally remain inside the 1V<sub>P-P</sub> limit (a notable exception is the chroma ramp used for

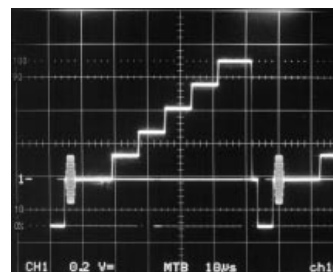

Figure 1. Typical 1V<sub>P-P</sub> Video Waveform (Several Lines Overlaid)

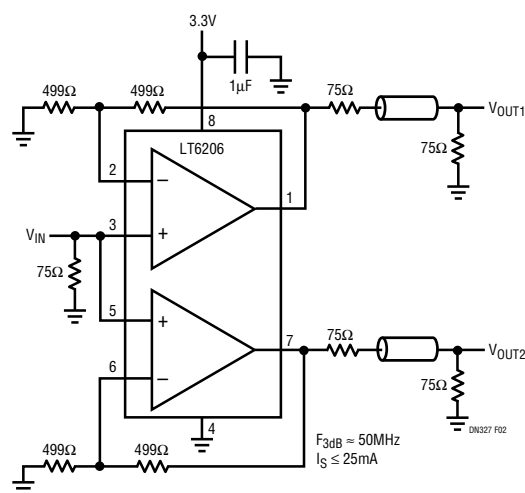

Figure 2. DC-Coupled Dual Composite Video Driver Powered from 3.3V

differential gain and differential phase measurements, which can reach 1.15V<sub>P-P</sub>).

### Amplifier Considerations

Most video amplifiers drive cables that are series terminated (back terminated) at the source and load terminated at the destination with resistances equal to the cable characteristic impedance,  $Z_0$  (usually 75Ω). This configuration forms a 2:1 resistor divider in the cabling that must be corrected in the driver amplifier by delivering 2V<sub>P-P</sub>

LT, LTC and LT are registered trademarks of Linear Technology Corporation.

output into an effective  $2 \cdot Z_0$  load (e.g.  $150\Omega$ ). Driving the cable can require in excess of 13mA while the output is approaching the saturation limits of the amplifier output. The absolute minimum supply is  $V_{MIN} = 2 + V_{OH} + V_{OL}$ , where the  $V_O$  values represent the minimum voltage drops that an amplifier can be guaranteed to develop with respect to the appropriate supply rail.

For example, the LT6206 dual operating on 3.3V in Figure 2, with exceptionally low  $V_{OH} \leq 0.5V$  and  $V_{OL} \leq 0.35V$ , provides a design margin of 0.45V, enough to cover supply variations and DC bias accuracy for the DC-coupled video input.

### Handling AC-Coupled Video Signals

Unfortunately, one cannot always be assured that source video has the appropriate DC content to satisfy the amplifier involved, so other design solutions are frequently required. AC-coupled video inputs are intrinsically more difficult to handle than those with DC-coupling because the average signal voltage of the video waveform is effected by the picture content, meaning that the black level at the amplifier wanders with scene brightness. By analyzing the worst-case wander, we can determine the AC-coupled constraint.

Figure 3 shows two superimposed AC-coupled waveforms, the higher trace being black field and the lower trace being white field. The wander is measured as 0.56V for the 1V<sub>P-P</sub> NTSC waveform shown, so an additional 1.12V allowance must be made in the amplifier supply (assuming gain of 2, so  $V_{MIN} = 3.12 + V_{OH} + V_{OL}$ ). The amplifier output (for gain of 2) must swing 1.47V to -1.65V around the DC-operating point, so the biasing circuitry needs to be designed accordingly for optimal fidelity. For example, an LT6551 operating on 5V, with excellent  $V_{OH} \leq 0.8V$  and  $V_{OL} \leq 0.2V$ , has a healthy design margin of 0.88V for a composite signal.

A popular method of further minimizing supply requirements with AC-coupling is to employ a simple clamping scheme as shown in Figure 4. In this circuit, the LT6205 is able to operate from 3.3V by having the sync-tips control the charge on the coupling capacitor, thereby reducing the black-level input wander to  $\approx 0.07V$ . A

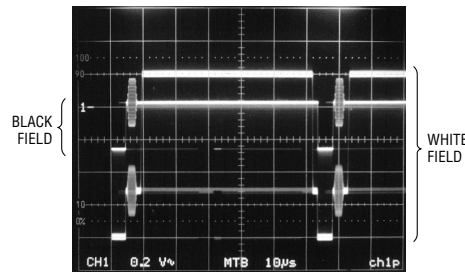

**Figure 3. Video Offset Shift Due to Picture Content with Conventional AC Coupling**

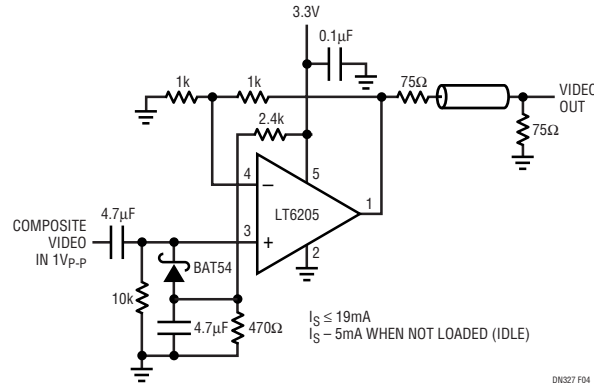

**Figure 4. AC-Coupled Clamped Video Amplifier Powered from 3.3V**

minor drawback to this circuit is the slight sync-tip compression ( $\approx 0.025V$  at input) due to the diode conduction current, though the picture content retains full fidelity. This circuit has nearly the design margin of its DC-coupled counterpart, at 0.31V (for this circuit,  $V_{MIN} = 2.14 + V_{OH} + V_{OL}$ ).

### Conclusion

With the industry's lowest output saturation characteristics, the low voltage video amplifiers, including the LT6205 (single), LT6206 (dual), LT6207 (quad), LT6550 (triple, fixed gain of 2) and LT6551 (quad, fixed gain of 2), offer the video designer the ability to share reduced supply voltages along with the logic circuitry. This ability to share supply voltages helps save space and cost by reducing power dissipation and power converter complexity.

#### Data Sheet Download

<http://www.linear.com/go/dnLT6205>  
<http://www.linear.com/go/dnLT6206>  
<http://www.linear.com/go/dnLT6207>

For applications help,  
 call (408) 432-1900, Ext. 2156