

# DESIGN NOTES

## Precise Gain Without External Resistors – Design Note 348

Glen Brisebois

### Introduction

Inventory and manufacturing have associated costs and logistical headaches. “If only we could simplify our stock room and our manufacturing kits.” The LT<sup>®</sup>1991 provides so many functions that it may be the last amplifier you ever have to stock. This is *not* a limited-use single-application difference or instrumentation amplifier. This is a flexible part that can be configured into inverting, noninverting, difference amplifiers, and even buffered attenuators, just by strapping its pins. It provides you with internal precisely matched resistors and feedback capacitors, so you can easily configure it into hundreds of different gain circuits without external components.

The LT1991 offers the simplicity of using just one amplifier for unlimited applications—simply hook it up for type and gain and move on. The precisely matched internal resistors, op amp, and feedback capacitor simplify design, reduce external complexity and test time, lower pick and place costs, and make for easy probing. All of this in a small MSOP package.

### The Resistors: 0.04% Worst Case

The LT1991 is shown in Figure 1. The internal resistors offer 0.04% worst-case matching and 3ppm/°C MAX matching temperature coefficient. They are nominally 50k, 150k and 450k. One end of each resistor is connected to an op amp input, and the other is brought out to a pin. The pins are named “M” or “P” depending on whether its resistor goes to the “minus” or “plus” input, and numbered “M1” M3” or “P9” etcetera according to the relative admittance of the resistor. So the “P9” pin has 9 times the admittance (or force) of the “P1” pin. The 450k resistors connected to the M1 and P1 inputs are not diode clamped, and can be taken well outside the supply rails.

### The Op Amp: Precision, Micropower

The op amp is exceptionally precise, with 15 $\mu$ V typical input offset voltage, 3nA input bias current and 50pA of input offset current. It operates on supplies from 2.7V to 36V with rail-to-rail outputs, and remains stable while

driving capacitive loads up to 500pF. Gain bandwidth product is 560kHz, while drawing only 100 $\mu$ A supply current.

### So Easy to Use

The LT1991 is exceptionally easy to use. Drive or ground or float the P, M, and REF inputs to set the configuration and gain. The M1 and P1 inputs of the LT1991 are not diode clamped, so they can withstand  $\pm 60$ V of common mode voltage. There is a whole series of high input common mode voltage circuits that can be created simply by just strapping the pins. Figure 2 shows a few examples of different configurations and gains. In fact, there are over 300 unique achievable gains in the noninverting configuration alone. Gains of up to 14 and buffered attenuations down to 0.07 are possible.

LTC and LT are registered trademarks of Linear Technology Corporation.

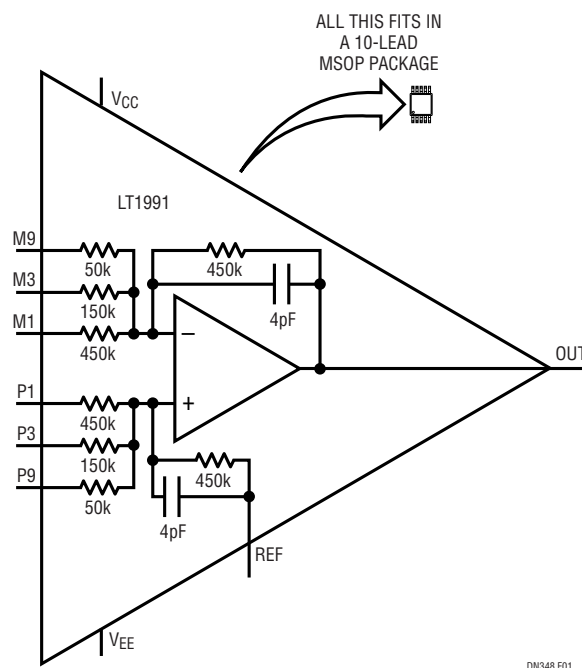
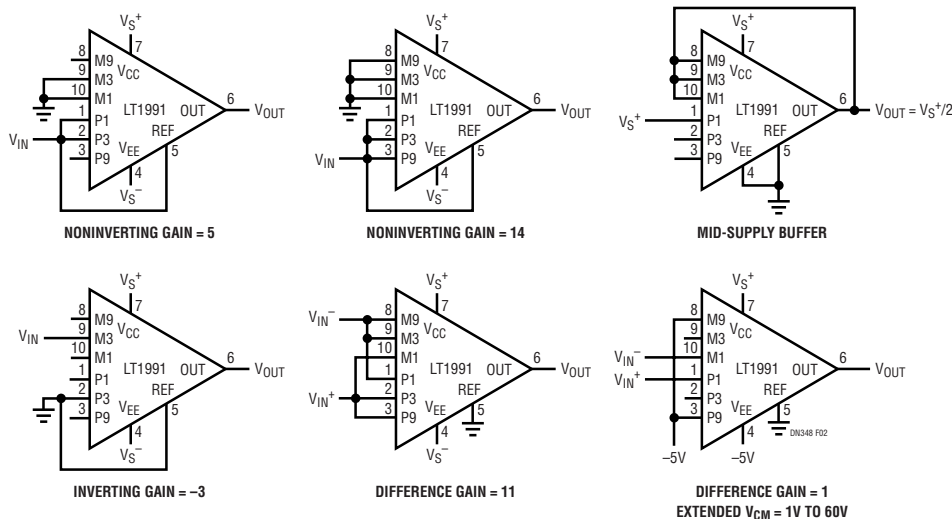

Figure 1. The LT1991 is a Ready-to-Use Op Amp with its Own Resistors and Internal Signal Capacitors, All in a Tiny MSOP package. Just Wire it Up



**Figure 2. Noninverting, Inverting, Difference Amplifier and Buffered Attenuators: Just a Few Examples Achieved Simply by Connecting Pins on the LT1991. No External Resistors Required**

### Battery Monitor Circuit

Many batteries are composed of individual cells with working voltages of about 1.2V each, as for example NiMH and NiCd. Higher total voltages are achieved by placing these in series. However, the reliability of the entire battery pack is limited by the weakest cell, so users often like to maintain data on individual cell charge characteristics and histories. Figure 3 shows the LT1991 configured as a difference amplifier in a gain of 3, applied across the individual cells of a battery through a dual 4:1 mux. Because of the high valued 150k resistors on its M3 and P3 inputs, the error introduced by the mux impedance is negligible. As the mux is stepped through its addresses, the LT1991 takes each cell voltage, multiplies it by 3 and references it to ground for easiest measurement. Note that worst-case combinations, such as one cell much higher than all the others, can cause the LT1991 output to clip. Connecting the MSB line to the M1 and P1 inputs helps reduce the effect of the wide input common mode fluctuations from cell to cell. The low supply current of the LT1991 makes it particularly suited to battery-powered applications. With its 110µA maximum supply current specification, it has about the same maximum supply current specification as the CMOS mux!

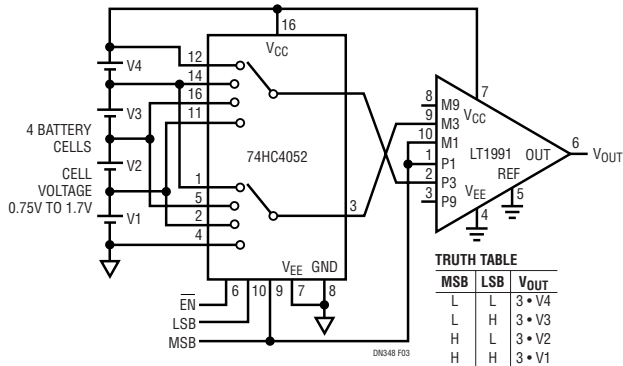

**Figure 3. LT1991 Applied as an Individual Battery Cell Monitor for a 4-Cell Battery**

### Conclusion

The precision LT1991 is so simple to use, small, and versatile, it is possible to stock this one amplifier and use it for many varied applications. No external components are needed to achieve hundreds of gains in noninverting, inverting, difference and attenuator configurations. Just strap the pins and go. It's a great way to reduce inventory, ease manufacturing, and simplify a bill of materials.

**Data Sheet Download**

<http://www.linear.com>

For applications help,  
call (408) 432-1900, Ext. 2156