

# DESIGN NOTES

## Programmable Baseband Filter for Software-Defined UHF RFID Readers

Design Note 432

Philip Karantzalis

### Introduction

Radio frequency identification (RFID) is an auto-ID technology that identifies any object that contains a coded tag. A UHF RFID system consists of a reader (or interrogator) that transmits information to a tag by modulating an RF signal in the 860MHz–960MHz frequency range. Typically, the tag is passive—it receives all of its operating energy from a reader that transmits a continuous-wave (CW) RF signal. A tag responds by modulating the reflection coefficient of its antenna, thereby backscattering an information signal to the reader.

Tag signal detection requires measuring the time interval between signal transitions (a data “1” symbol has a longer interval than a data “0” symbol). The reader initiates a tag inventory by sending a signal that instructs a tag to set its backscatter data rate and encoding. RFID readers can operate in a noisy RF environment where many readers are in close proximity. The three operating modes, single-interrogator, multiple interrogator and dense-interrogator, define the spectral limits of reader and tag signals. Software programmability of the receiver provides an optimum balance of reliable multitag detection and high data throughput. The programmable reader contains a high linearity direct conversion I and Q demodulator, low noise amplifiers, a dual baseband filter with variable gain and bandwidth and a dual analog-to-digital converter (ADC). The LTC6602 dual, matched, programmable bandpass filter can optimize high performance RFID readers.

### The LTC6602 Dual Bandpass Filter

The LTC6602 features two identical filter channels with matched gain control and frequency-controlled lowpass, and highpass networks. The phase shift through each channel is matched to  $\pm 1$  degree. A clock frequency, either internal or external, positions the pass band of the filter at the required frequency spectrum.

The lowpass and highpass corner frequencies, as well as, the filter bandwidth are set by division ratios of the

clock frequency. The lowpass division ratio options are 100, 300 and 600 and the highpass division ratios are, 1000, 2000, 6000. Figure 1 shows a typical filter response with a 90MHz internal clock and the division ratios set to 6000 and 600 for the highpass and lowpass, respectively. A sharp 4th order elliptical stopband response helps eliminate out-of-band noise. Controlling the baseband bandwidth permits software definition of the operating mode of the RFID receiver as it adapts to the operating environment.

### An Adaptable Baseband Filter for an RFID Reader

Figure 2 shows a simple LTC6602-based filter circuit that uses SPI serial control to vary the filter’s gain and bandwidth to adapt to a complex set of data rates and encoding. (The backscatter link frequency range is 40kHz to 640kHz and the data rate range is 5kbps to 640kbps.)

For fine resolution positioning of the filter, the internal clock frequency is set by an 8-bit LTC2630 DAC. A 0V to 3V DAC output range positions the clock frequency between 40MHz and 100MHz (234.4kHz per bit). The lowpass and highpass division ratios are set by serial

LT, LTC and LTM are registered trademarks of Linear Technology Corporation. All other trademarks are the property of their respective owners.

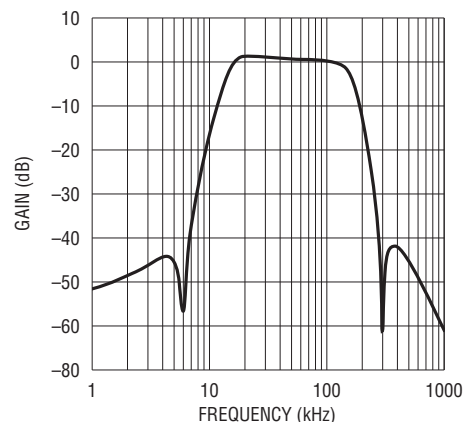

Figure 1. Filter Response for a 15kHz–150kHz Passband

SPI control of the LTC6602. The cutoff range for the highpass filter is 6.7kHz to 100kHz and 66.7kHz to 1MHz for the lowpass filter. The optimum filter bandwidth setting can be adjusted by a software algorithm and is a function of the data clock, data rate and encoding. The filter bandwidth must be sufficiently narrow to maximize the dynamic range of the ADC input and wide enough to preserve signal transitions and pulse widths (the proper filter setting ensures reliable DSP tag signal detection).

Figure 3 shows an example of the filter's time domain response to a typical tag symbol sequence (a "short" pulse interval followed by a "long" pulse interval). The lowpass cutoff frequency is set equal to the reciprocal of the shortest interval ( $f_{CUTOFF} = 1/10\mu s = 100kHz$ ). If the lowpass cutoff frequency is lower, the signal transition and time interval will be distorted beyond recognition. The setting of the highpass cutoff frequency is more qualitative than specific. The highpass cutoff frequency must be lower than the reciprocal of the longest interval (for

the example shown, highpass  $f_{CUTOFF} < 1/20\mu s$ ) and as high as possible to decrease the receiver's low frequency noise (of the baseband amplifier and the down-converted phase and amplitude noise). The lower half of Figure 3 shows the filter's overall response (lowpass plus highpass filter). Comparing the filter outputs with a 10kHz and a 30kHz highpass setting, the signal transitions and time intervals of the 10kHz output are adequate for detecting the symbol sequence (in an RFID environment, noise will be superimposed on the output signal). In general, increasing the lowpass  $f_{CUTOFF}$  and/or decreasing the highpass  $f_{CUTOFF}$  "enhances" signal transitions and intervals at the expense of increased filter output noise.

### Conclusion

The LTC6602 dual bandpass filter is a programmable baseband filter for high performance UHF RFID readers. Using the LTC6602 under software control provides the ability to operate at high data rates with a single interrogator or with optimum tag signal detection in a multiple or dense interrogator physical setting. The LTC6602 is a very compact IC in a 4mm x 4mm QFN package and is programmable with parallel or serial control.

### References:

1. *The RF in RFID*, Daniel M. Dobkin, 9/07, Elsevier Inc.
2. *Class-1 Generation-2 UHF RFID Protocol for Communications at 860 MHz to 960 MHz*, Version 1.1.0, [www.epcglobalinc.org/standards/specs/](http://www.epcglobalinc.org/standards/specs/)

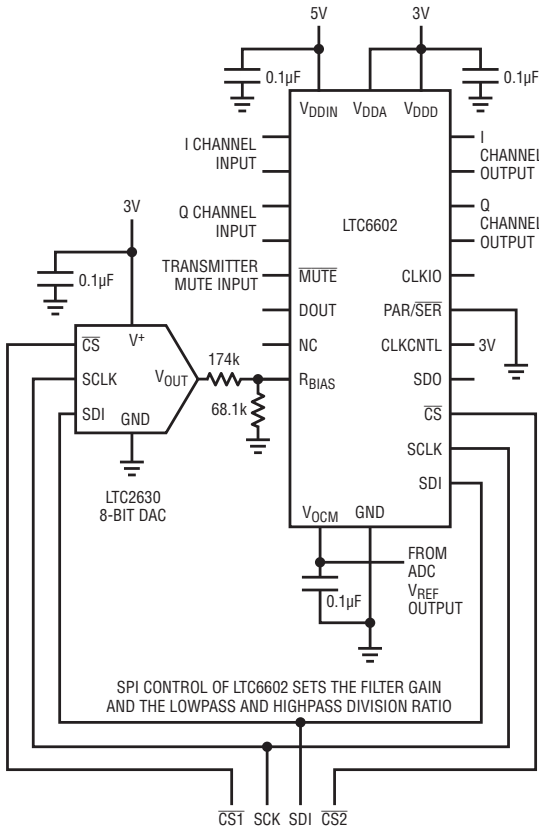

**Figure 2. An Adaptable RFID Baseband Filter with SPI Control**

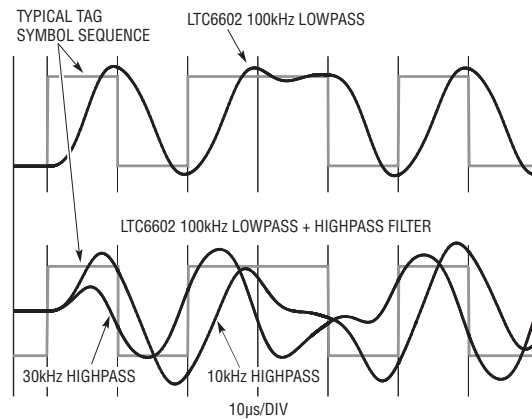

**Figure 3. Filter Transient Response to a Tag Symbol Sequence**

[Data Sheet Download](#)

[www.linear.com](http://www.linear.com)

For applications help,  
call (408) 432-1900, Ext. 2020