

Precision, Matched, Baseband Filter ICs Outperform Discrete Implementations – Design Note 476

Philip Karantzalis

Introduction

In digital communication systems, baseband signals must be band-limited in the transmitter or the receiver. Although the bulk of baseband signal shaping and analysis is accomplished using digital signal processing (DSP), analog filtering is used in a number of places along the signal chain. For instance analog filters reduce the imaging of a digital-to-analog converter (DAC), filter out the high frequency noise of an RF demodulator or reduce the aliasing inputs of an analog-to-digital converter (ADC).

Typically, 3G communication systems (CDMA, GSM, UMTS or WiMax) feature a baseband channel bandwidth of 1.25MHz to over 20MHz. In this frequency range, discrete analog filters—those constructed with high speed op amps, resistors and capacitors—are sensitive to PCB layout parasitics, component tolerances and mismatches. The pitfalls of using discrete components can be avoided by using integrated, pin-configurable, precision analog filter ICs, such as the LTC6601-1/-2 and the LTC6605-7/-10/-14. The LTC6601-x is a single 2nd order lowpass filter and the LTC6605-x is a dual, matched filter.

The LTC6601-x Lowpass Filter

Figure 1 shows a block diagram of an LTC6601-x and the 2nd order function it implements. High frequency filters are easily implemented using the LTC6601-x, which integrates a low noise (1.5nV/√Hz) wideband (600MHz), fully differential amplifier with precision resistors and capacitors. The standard deviation of the on-chip resistors and capacitors is ±0.25% and their matching is ±0.1% (in a differential amplifier, the common mode rejection at high frequencies depends on tight matching of the signal paths). Furthermore, the gain bandwidth (GBW) of the LTC6601-x amplifier is trimmed to ±5%. Note that this level of precision cannot be achieved with discrete analog filters in any practical manufacturing process.

In many LTC6601-x filter implementations, no external components are required. For instance, lowpass filters can be produced by simply hardwiring the input pins for

a variety of filter gain and cutoff frequencies from 5MHz to 27MHz.

The product and ratio of the on-chip resistors and capacitors determine the f_0 and Q values of the 2nd order filter function. The f_0 and Q pair sets the filter's cutoff frequency and passband gain peak. The value of the feedback resistor determines the range of the f_0 frequencies. The 400Ω feedback resistors can be shunted by input resistors to increase the f_0 range.

Using an LTC6601-x with input RC or LC filters, 3rd, 4th and 5th order lowpass filters can be implemented (refer to the LTC6601-1 or -2 data sheets for higher order filter options).

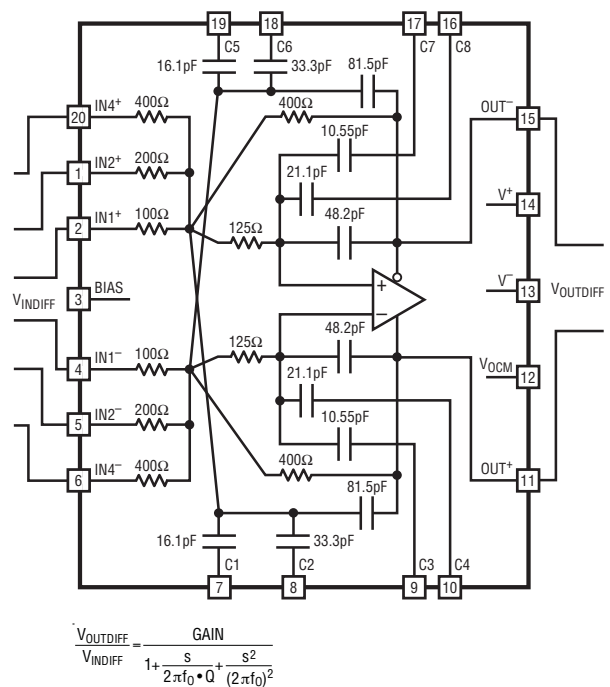

Figure 1. Block Diagram of the LTC6601-x and the 2nd Order Transfer Function it Implements.

LT, LT, LTC, LTM, Linear Technology, the Linear logo are registered trademarks of Linear Technology Corporation. All other trademarks are the property of their respective owners.

The LTC6601 family is offered in two options that trade off distortion and noise. Use the LTC6601-1 for low noise and the LTC6601-2 for low distortion at low power.

The LTC6605-x, Dual, Matched, Lowpass Filter

Typically, quadrature down conversion is used in a direct conversion or zero-IF receiver. In a quadrature demodulator, the RF signal is split into two paths and mixed with the LO (local oscillator) to produce an I (in phase) and a Q (90° phase or quadrature) signal. In a direct conversion receiver, high image rejection depends on very tight gain and phase matching. High image rejection maximizes the signal-to-noise ratio (SNR) and minimizes the bit error rate.

The LTC6605-x contains two LTC6601 ICs configured and tested as a dual, matched, 2nd order, lowpass filter. There are three LTC6605 versions: the LTC6605-7 with an adjustable $f_{(-3dB)}$ range of 6.5MHz to 10MHz, the LTC6605-10 with an adjustable $f_{(-3dB)}$ range of 9.7MHz to 14MHz and the LTC6605-14 with an adjustable $f_{(-3dB)}$ range of 12.4MHz to 20MHz (the $f_{(-3dB)}$ or $f_{(-1dB)}$ frequency is set by an external resistor).

The maximum gain and phase matching error of an LTC6605-x is $\pm 0.35dB$ and $\pm 1.2^\circ$ respectively (equivalent to $-32dB$ of image rejection). This level of gain and phase matching of an LTC6605-x IC is impractical using discrete resistors and capacitors.

The LTC6605-7 or -10 input pins can be hard wired for gains of 1, 4 or 5; the LTC6605-14 for gains of 1, 2 or 3. Either

can produce noninteger gains using external input resistors with a slight reduction in gain and phase matching.

Accurate gain and phase matching, when combined with very low noise and distortion, allows for a high dynamic range differential circuit. Figure 2 shows an LTC6605-7 driving a dual LTC2205 16-bit ADC and Figure 3 shows the FFT plot of the ADC output. The LTC6605-7 is configured for a 12dB gain and a 7MHz, $-1dB$ frequency (suitable application for WiMax).

As with an LTC6601-x, an LTC6605-x can be used with input RC or LC filters, to implement 3rd, 4th and 5th order lowpass filters. The LTC6605-7 is available in a compact 6mm x 3mm, 22-pin leadless DFN package.

The power consumption for an LTC6601-x and for each LTC6605-x 2nd order section, is set by a three-state BIAS pin, allowing a choice between shutdown ($I_S = 350\mu A$), medium power ($I_S = 16mA$) or full power ($I_S = 33mA$).

Conclusion

The LTC6601-x fully differential, lowpass filter with precision on-chip resistors and capacitors can be configured by hardwiring pins to implement 2nd order filters in a frequency range of 5MHz to 27MHz.

The LTC6601-x is insensitive to PCB parasitics and is a higher performance circuit than a discrete analog filter. The LTC6605-x is a dual, matched, 2nd order lowpass filter for driving dual ADCs in a high performance direct conversion receiver. Using RC or LC filters with an LTC6601-x or LTC6605-x, 3rd, 4th or 5th order lowpass filters can be implemented.

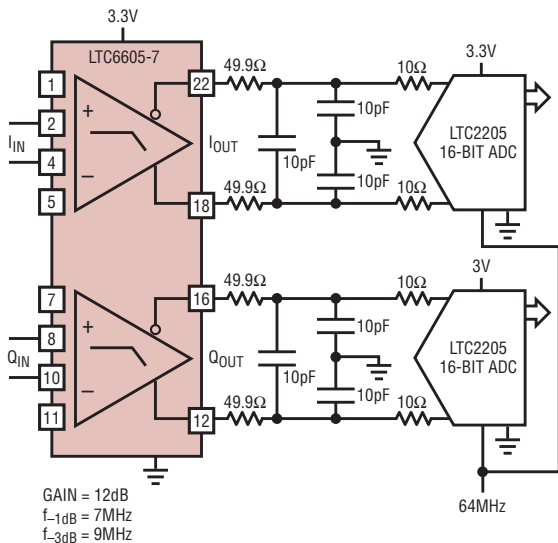

Figure 2. An LTC6605-7 Driving Two LTC2205 ADCs

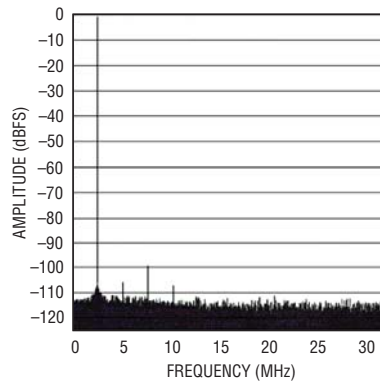

Figure 3. The FFT Plot of the LTC2205's I or Q Output Channels of Figure 2 (75dB SNR, $-98dB$ SFDR, 64K-Point FFT, 64MSPs, $f_{IN} = 2.5MHz$, $-1dBFS$).

Data Sheet Download

www.linear.com

For applications help,
call (408) 432-1900, Ext. 3761

Linear Technology Corporation
1630 McCarthy Blvd., Milpitas, CA 95035-7417
(408) 432-1900 • FAX: (408) 434-0507 • www.linear.com

dn476f LT/TP 0310 116K • PRINTED IN THE USA



www.BDTIC.com/Linear

© LINEAR TECHNOLOGY CORPORATION 2010