



Adjustable LED blinking frequency using a potentiometer and STM8SVLDISCOVERY

Application overview

This document introduces a very simple application example which is ideal for beginners to learn about the STM8SVLDISCOVERY and its programming environment.

This application adjusts the blinking frequency of a string of 4 LEDs using a potentiometer. The ADC measures the analog voltage present at the potentiometer bridge, and the blinking frequency of the LEDs is adjusted accordingly.

This application automatically starts as soon as the STM8SVLDISCOVERY is powered-up through a standard USB cable connected to the host PC, and the LEDs start blinking at a speed dependant on the potentiometer position.

Note: Additional hardware is required to run this application.

Built around the STM8S003K3T6, the STM8SVLDISCOVERY allows evaluation of the main features of all the STM8S Value line MCUs.

Reference documents

- STM8SVLDISCOVERY user manual (UM1482)
- STM8SVLDISCOVERY getting started (UM1480)
- Developing and debugging your STM8S application code user manual (UM0834)
- STM8S003 datasheet
- STM8S reference manual (RM0016)

Contents

- 1 Application description 5**
 - 1.1 Hardware required 5
 - 1.2 Application schematics 5
 - 1.3 Application principle 6

- 2 Software description 7**
 - 2.1 Touch sensing library configuration 7
 - 2.2 Standard STM8S standard firmware library configuration 8
 - 2.3 Application software flowcharts 9
 - 2.3.1 Main loop flowchart 9
 - 2.3.2 ExtraCode_StateMachine flowchart 10

- 3 Revision history 12**

List of figures

Figure 1.	Application schematics	5
Figure 2.	Main application loop flowchar	9
Figure 3.	ExtraCode_StateMachine flowchart	11

List of tables

Table 1.	LED LD1 configuration	6
Table 2.	Touch Sensing library configuration	7
Table 3.	Document revision history	12

1 Application description

1.1 Hardware required

No STM8SVLDISCOVERY on-board resources are used.

Additional hardware is required to make this application software run on the STM8SVLDISCOVERY:

- A potentiometer: 10 K
- 4 LEDs (LD2, LD3, LD4, LD5)
- 4 resistors (510 ohms)

1.2 Application schematics

Refer to UM1482 STM8SVLDISCOVERY for implementation details.

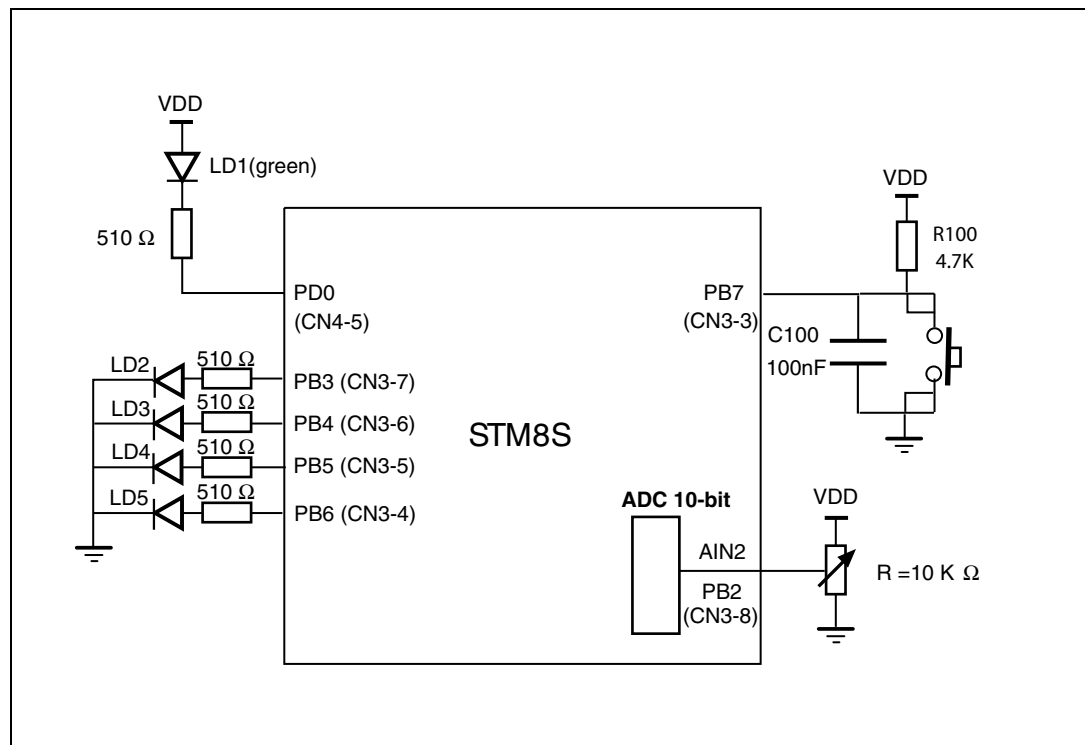

1.3 Application principle

This application uses the ADC (Analog-to-Digital Converter) to convert the analog output voltage delivered by the potentiometer (0V to VDD) into a 10-bit digital value in the range of 0x0 to 0x3FF. The application switches the 4 LEDs on and off sequentially in a circular way, making use of this digital value to adjust the time during which each LED is left switched on before switching it off and driving the next one.

As a consequence, the blinking frequency of the LED string is controlled by the potentiometer: the higher the resistance selected by the potentiometer, the higher the voltage output of the potentiometer wiper, the higher the 10-bit digital value converted by ADC, the lower the blinking frequency of the LED string.

The 10-bit ADC conversion result which is used to modulate the LEDs temporization has been scaled to get a sufficiently long delay so that the blinking can be seen distinctly whatever the position selected by the potentiometer.

Table 1. LED string blinking speed parameters

Vpot (volts)		ADC value	Cycle (4 LEDs) period
Vdd=5 V	Vdd=3 V		
0	0	0	68 ms
2.5	1.5	511	952 ms
5	3	1023	1800 ms

2 Getting started

This application automatically starts as soon as the STM8SVLDISCOVERY is powered-up through a standard USB cable connected to the host PC. The LEDs start blinking at a speed dependant on the potentiometer position.

2.1 Updating firmware

Before running this application, the STM8S program memory must be updated with the firmware associated to this application note. Read STM8SVLDISCOVERY getting started (UM1480) to see how to proceed.

2.2 Hardware settings

The power supply is provided by the USB connector and controlled by JP1 (5 V or regulated 3.3 V). In this application example you can use either source, the only impact is a variation in LED luminosity. For details about STM8SVLDISCOVERY refer to UM1482 STM8SVLDISCOVERY.

3 Software description

The application software does not use the STM8S standard firmware library to control general purpose functions, but directly programs peripheral registers.

The peripherals used are the following:

- Clock (CLK)
The clock control enables and delivers the correct clock frequency to the CPU and peripherals. At power-on, the master clock source is automatically selected as HSI clock with prescaler division factor equal to 8. Here we change the division factor to 0. So, $f_{\text{MASTER}} = 16 \text{ MHz}$
- GPIOs
The GPIOs drive the MCU I/Os to interface with external hardware. They configure port PB3, PB4, PB5 and PB6 as output push-pull low to drive the LEDs LD2, LD3, LD4 and LD5. Other ports are configured by default input floating.
- ADC
The 10-bit Analog-to-Digital Converter is used to convert the analog voltage delivered from the potentiometer. It is configured as:
 - Single conversion mode
 - Channel 2 (AIN2)
 - $f_{\text{ADC}} = f_{\text{MASTER}} / 8 \Rightarrow f_{\text{ADC}} = 2 \text{ MHz}$
 - Right alignment results

A simple software loop implements the delays that control the LEDs switch-on time. Use of a timer configured as a time-base generator allows better control of the delay accuracy. See STM8S standard library for examples of a time-base generator.

4 Revision history

Table 2. Document revision history

Date	Revision	Changes
25-Nov-2011	1	Initial release.

Please Read Carefully:

Information in this document is provided solely in connection with ST products. STMicroelectronics NV and its subsidiaries ("ST") reserve the right to make changes, corrections, modifications or improvements, to this document, and the products and services described herein at any time, without notice.

All ST products are sold pursuant to ST's terms and conditions of sale.

Purchasers are solely responsible for the choice, selection and use of the ST products and services described herein, and ST assumes no liability whatsoever relating to the choice, selection or use of the ST products and services described herein.

No license, express or implied, by estoppel or otherwise, to any intellectual property rights is granted under this document. If any part of this document refers to any third party products or services it shall not be deemed a license grant by ST for the use of such third party products or services, or any intellectual property contained therein or considered as a warranty covering the use in any manner whatsoever of such third party products or services or any intellectual property contained therein.

UNLESS OTHERWISE SET FORTH IN ST'S TERMS AND CONDITIONS OF SALE ST DISCLAIMS ANY EXPRESS OR IMPLIED WARRANTY WITH RESPECT TO THE USE AND/OR SALE OF ST PRODUCTS INCLUDING WITHOUT LIMITATION IMPLIED WARRANTIES OF MERCHANTABILITY, FITNESS FOR A PARTICULAR PURPOSE (AND THEIR EQUIVALENTS UNDER THE LAWS OF ANY JURISDICTION), OR INFRINGEMENT OF ANY PATENT, COPYRIGHT OR OTHER INTELLECTUAL PROPERTY RIGHT.

UNLESS EXPRESSLY APPROVED IN WRITING BY TWO AUTHORIZED ST REPRESENTATIVE, ST PRODUCTS ARE NOT RECOMMENDED, AUTHORIZED OR WARRANTED FOR USE IN MILITARY, AIR CRAFT, SPACE, LIFE SAVING, OR LIFE SUSTAINING APPLICATIONS, NOR IN PRODUCTS OR SYSTEMS WHERE FAILURE OR MALFUNCTION MAY RESULT IN PERSONAL INJURY, DEATH, OR SEVERE PROPERTY OR ENVIRONMENTAL DAMAGE. ST PRODUCTS WHICH ARE NOT SPECIFIED AS "AUTOMOTIVE GRADE" MAY ONLY BE USED IN AUTOMOTIVE APPLICATIONS AT USER'S OWN RISK.

Resale of ST products with provisions different from the statements and/or technical features set forth in this document shall immediately void any warranty granted by ST for the ST product or service described herein and shall not create or extend in any manner whatsoever, any liability of ST.

ST and the ST logo are trademarks or registered trademarks of ST in various countries.

Information in this document supersedes and replaces all information previously supplied.

The ST logo is a registered trademark of STMicroelectronics. All other names are the property of their respective owners.

© 2011 STMicroelectronics - All rights reserved

STMicroelectronics group of companies

Australia - Belgium - Brazil - Canada - China - Czech Republic - Finland - France - Germany - Hong Kong - India - Israel - Italy - Japan - Malaysia - Malta - Morocco - Philippines - Singapore - Spain - Sweden - Switzerland - United Kingdom - United States of America

www.st.com